



GF 420 - 4.1

95457





LIEFERUMFANG



> 20 kg



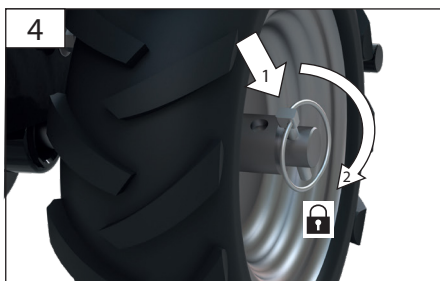
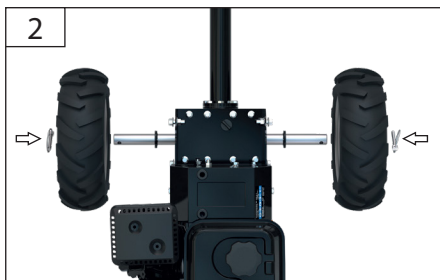

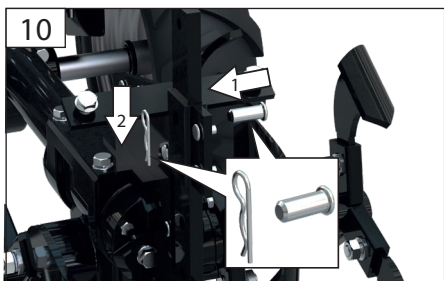
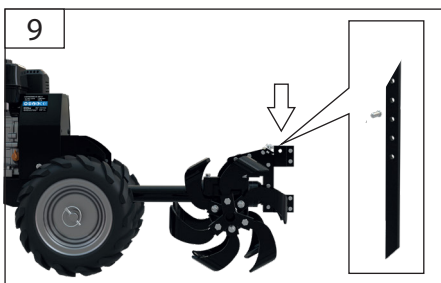
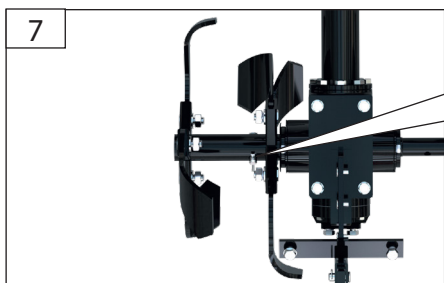
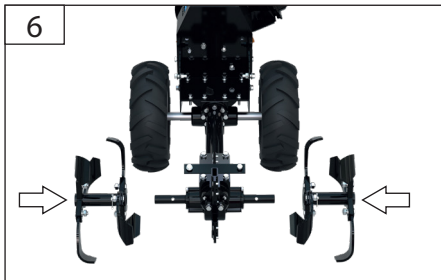

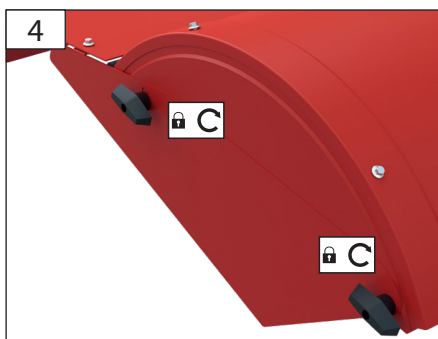
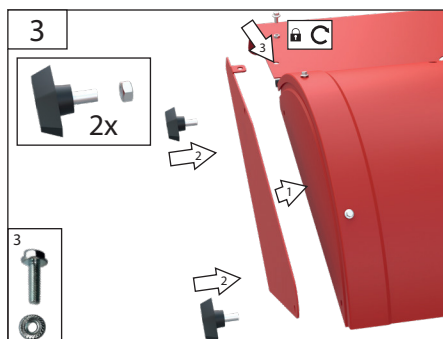
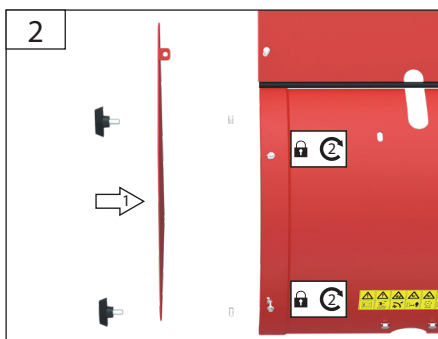
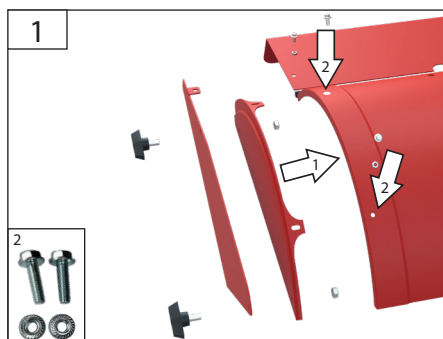
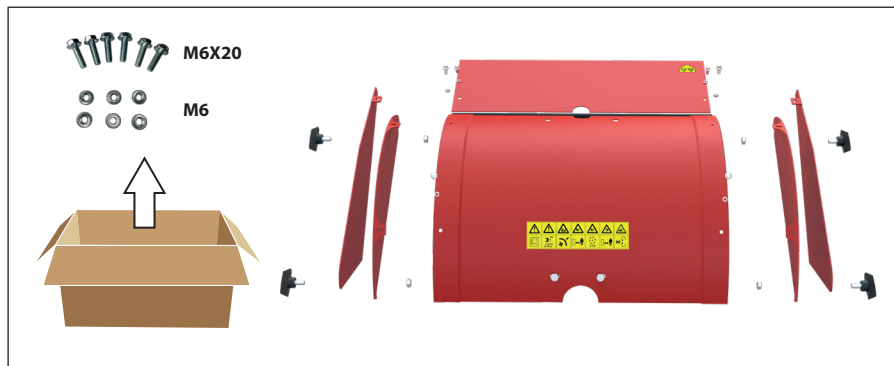

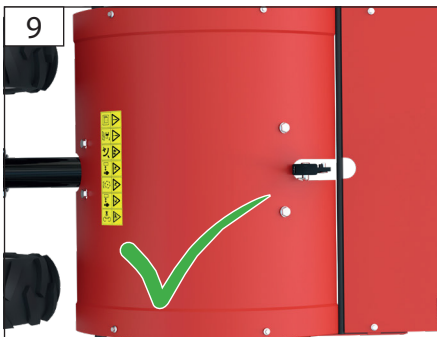
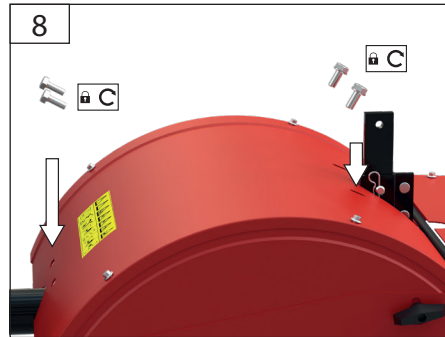
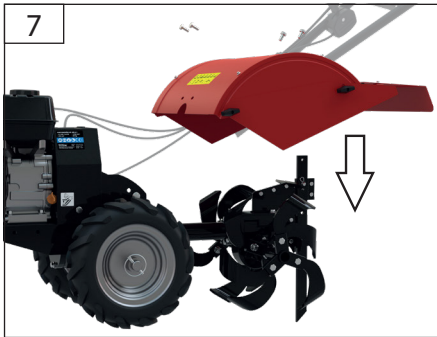
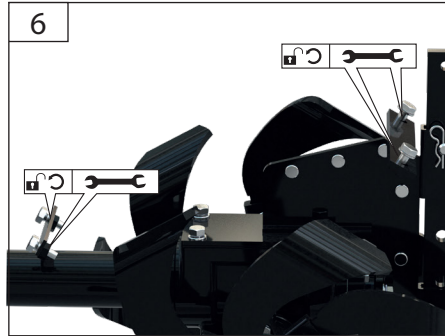
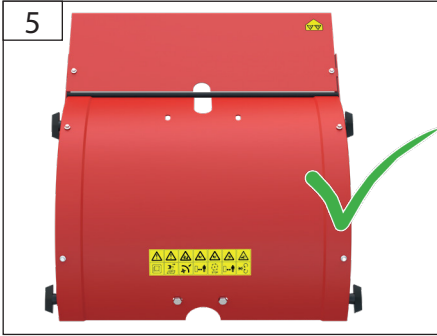

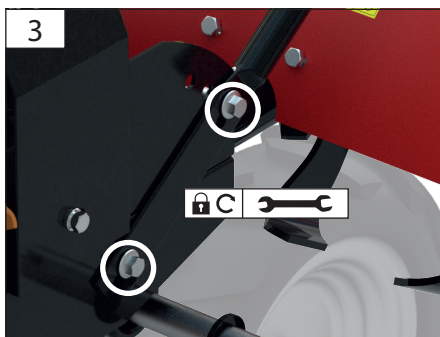
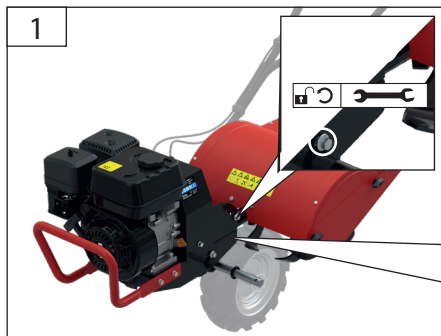

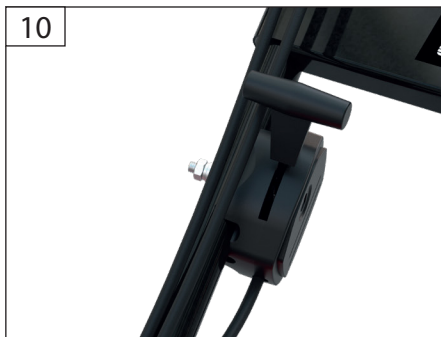
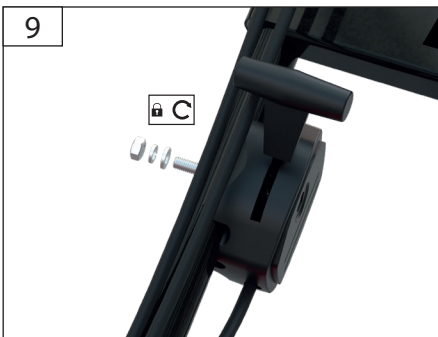
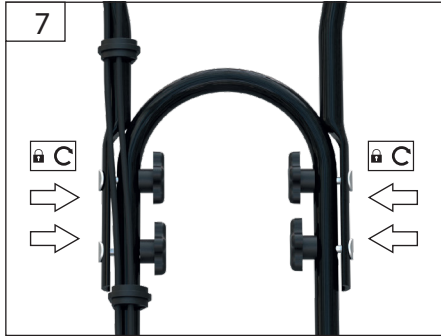
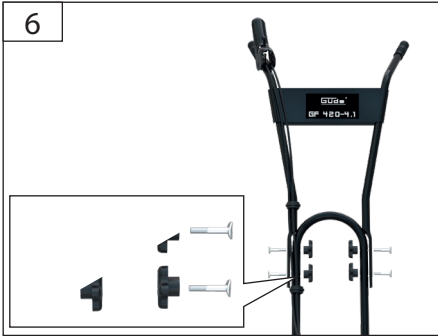

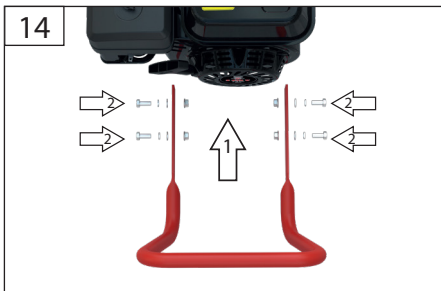
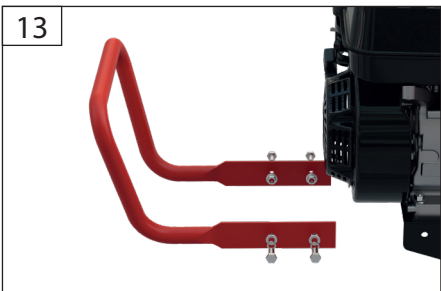
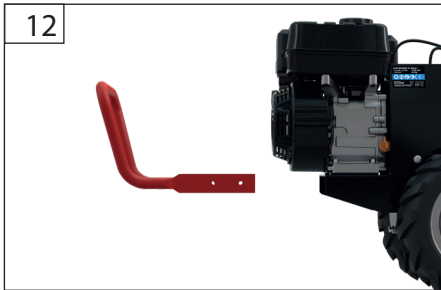
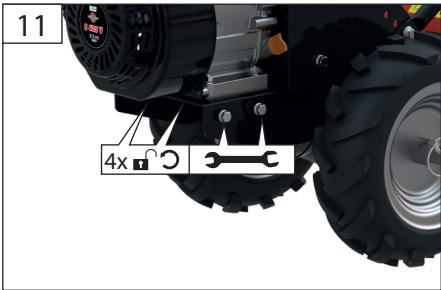



10W-40

DE Vor Erstinbetriebnahme muss der

**Motor unbedingt mit Motorenöl
befüllt werden. Überprüfen Sie vor
jeder Inbetriebnahme den Ölstand.**

1

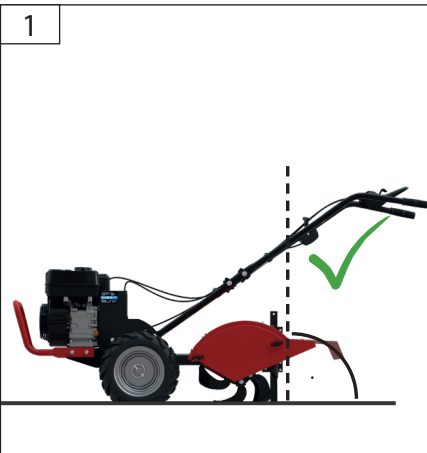

2

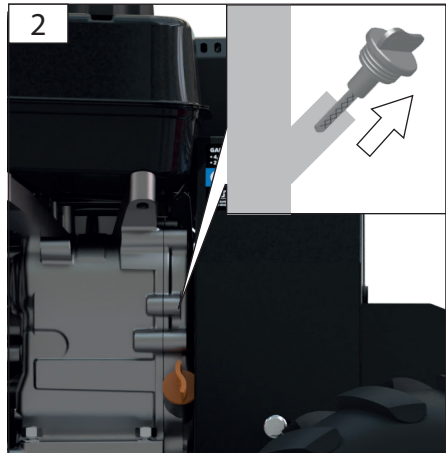

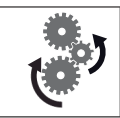

3

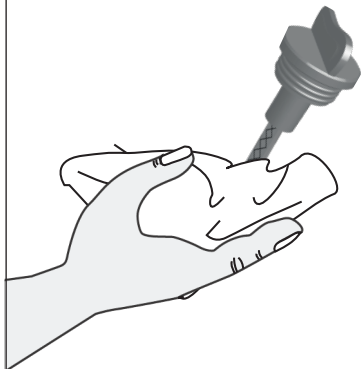

4

Test

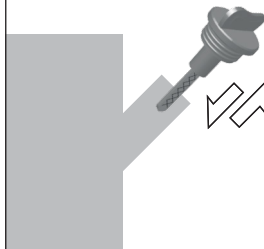
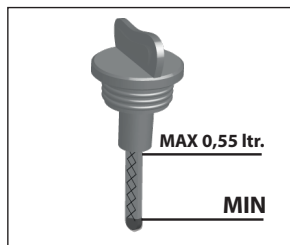

5

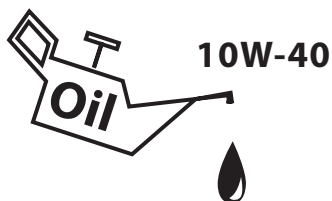

6

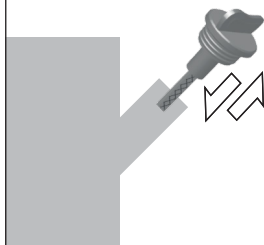
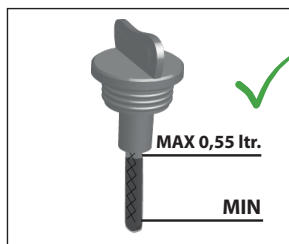



DE Aus Gründen der Qualitätssicherung

wird jedes Gerät einem Probelauf unterzogen und mit Motorenöl befüllt.

Vor dem Transport wird das Öl wieder abgelassen, es können sich jedoch Rückstände von Motorenöl am Messstab befinden. Bitte trotzdem Ölstand gewissenhaft überprüfen und Motorenöl nachfüllen. 7+8

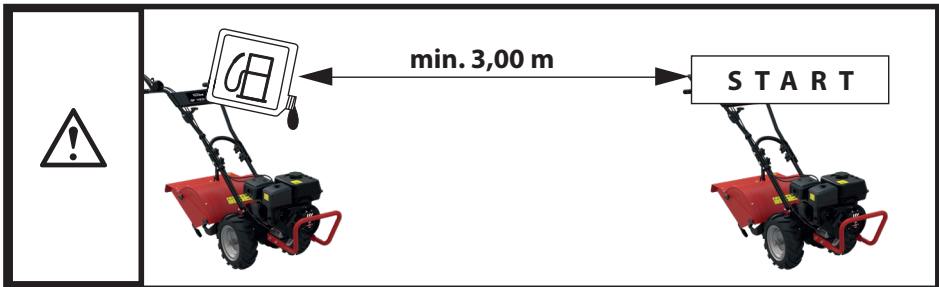
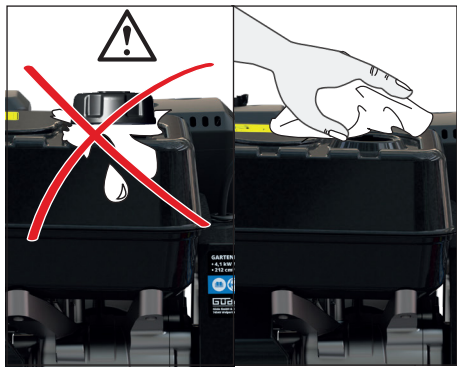
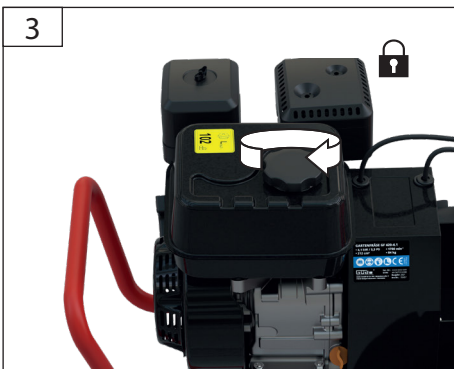
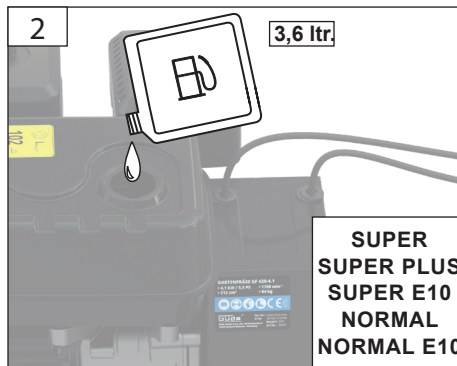
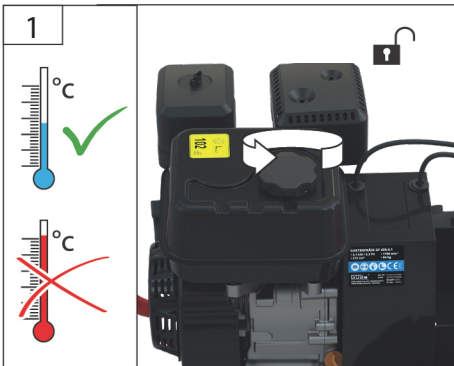
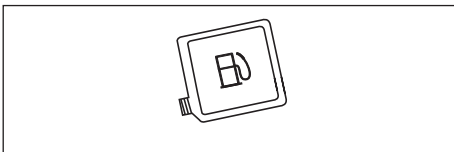
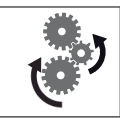



 **S5 DCT 11**

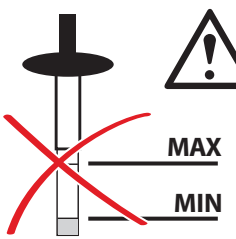
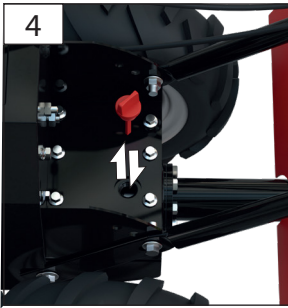
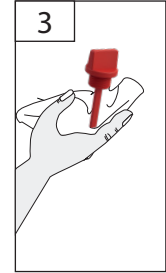
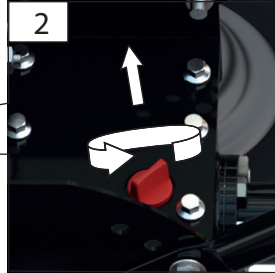



MAX

MIN

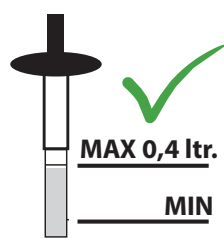

MAX 0,4 ltr.

MIN

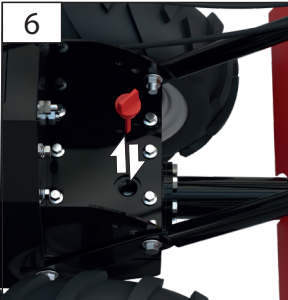
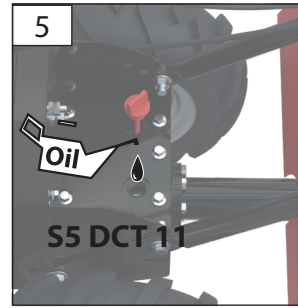

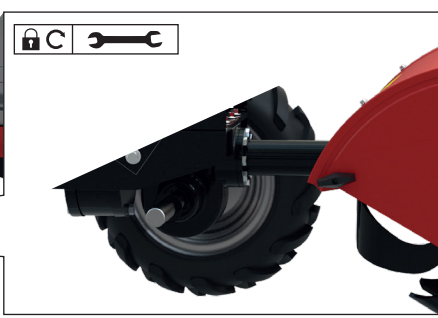
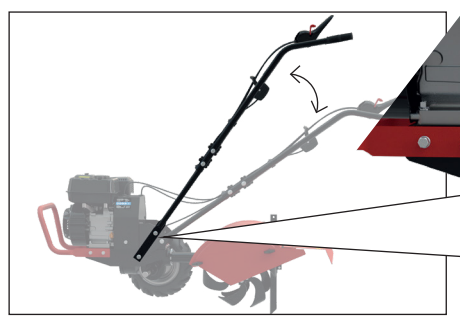
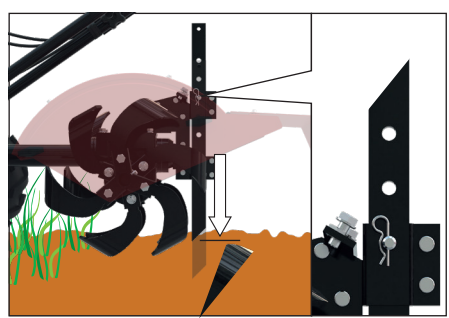
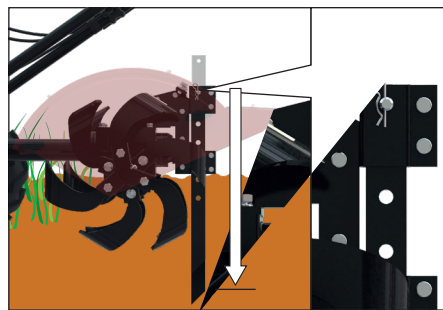



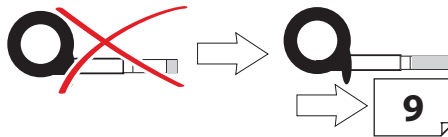

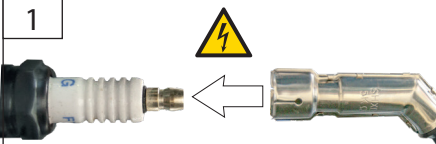
⚠️  **START**

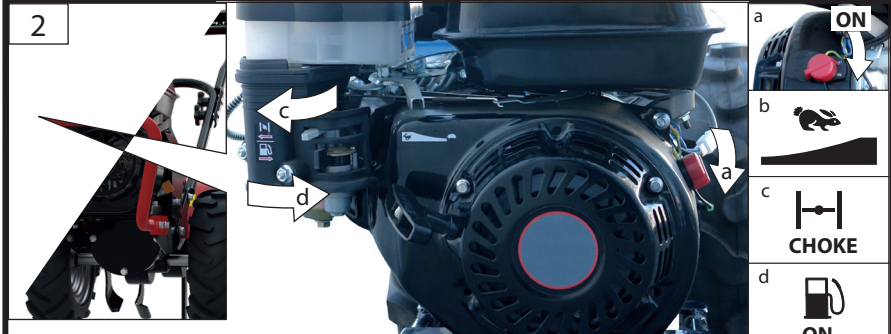
1 

2 

a **ON**

b 

c  **CHOKE**

d  **ON**

DE Choke muss nur geöffnet werden, wenn der Motor kalt ist.

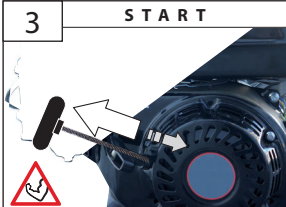

3 **START** 

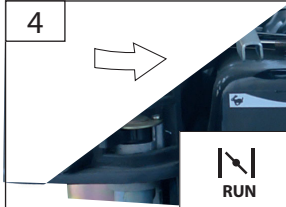
4  **RUN**



STOPP

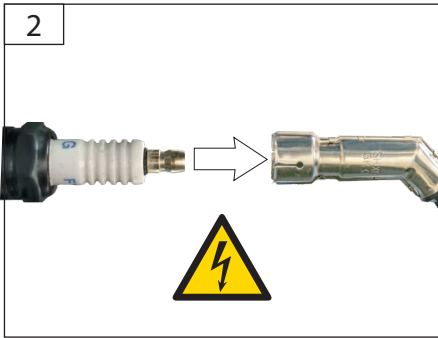
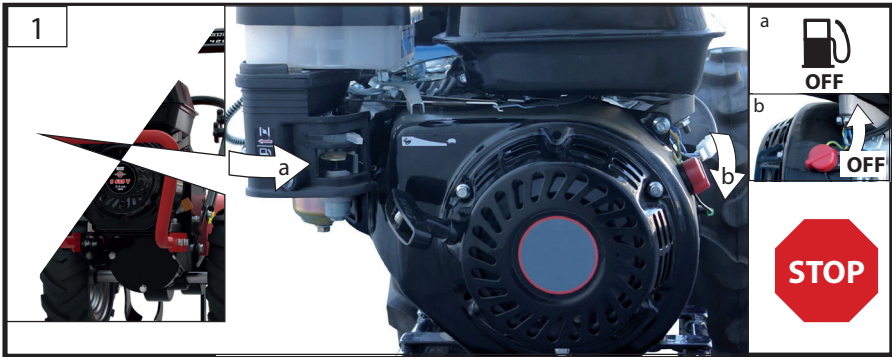



1



2a



2b

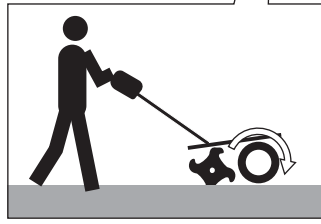
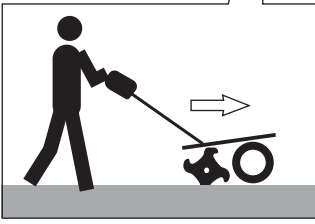

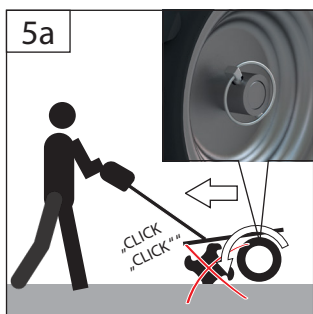
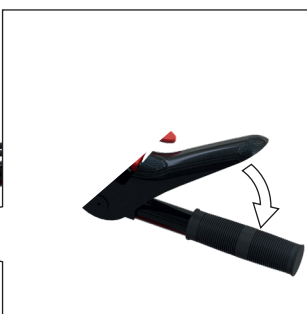
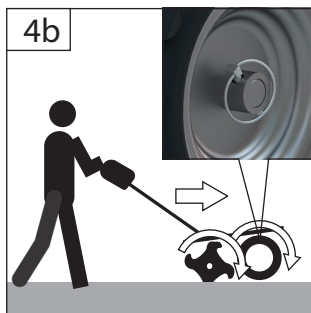
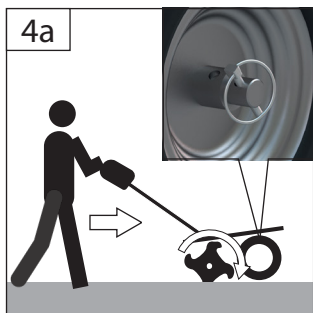
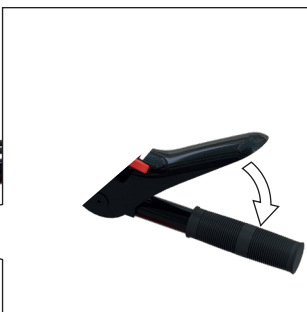

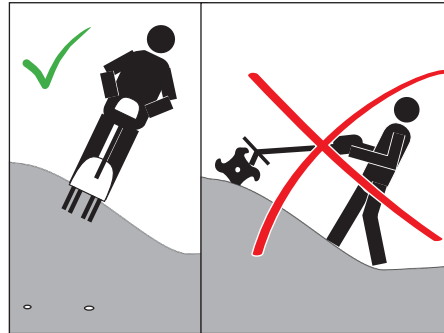
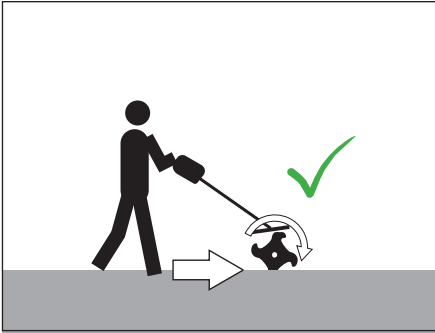

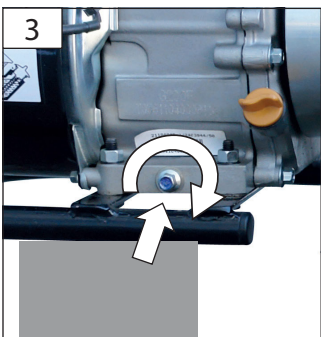
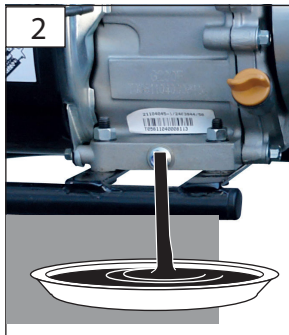
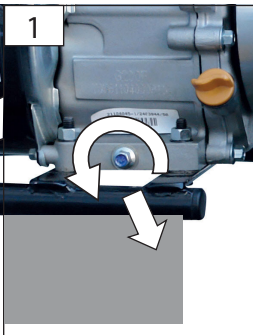
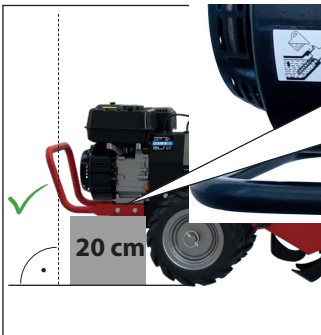
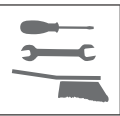

4

DE Ölstand auffüllen/kontrollieren! → **9**

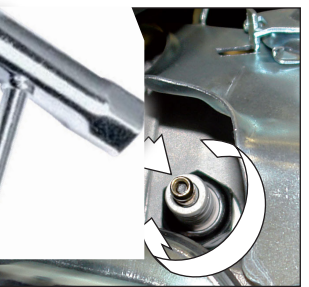
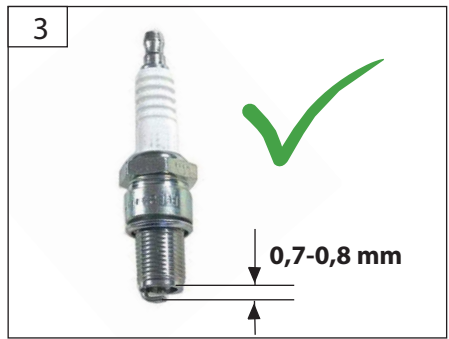
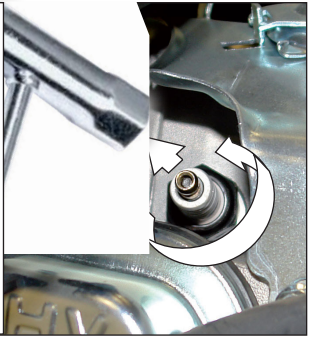
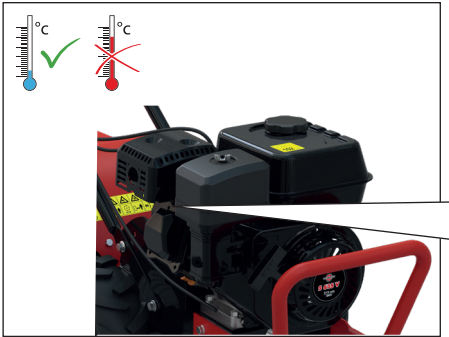

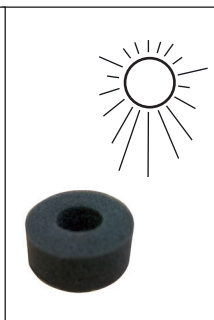
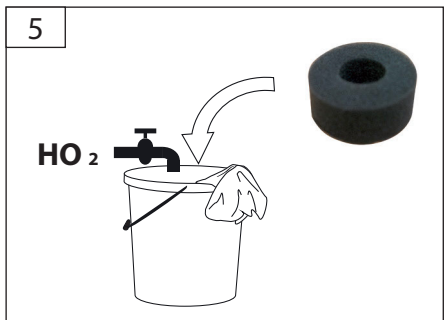
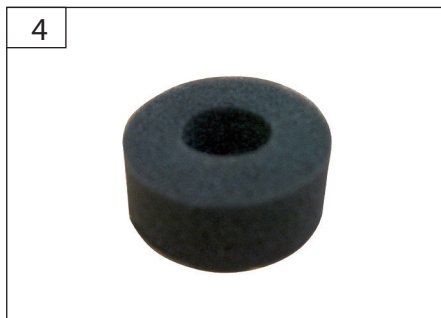
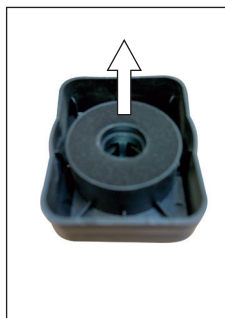
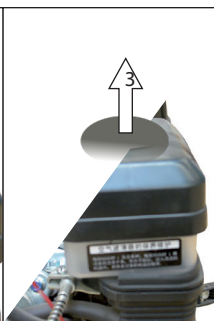
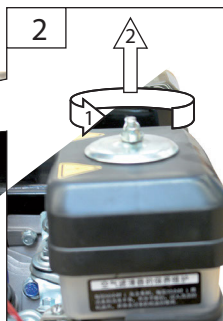
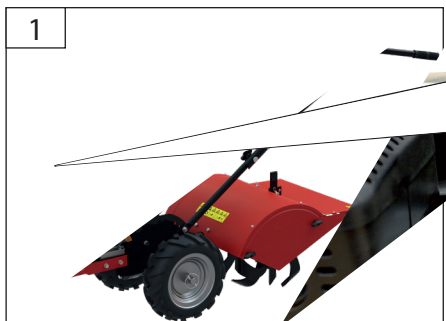
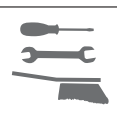

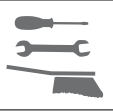

7

TIPP



DE Geben Sie ein paar Tropfen Öl auf den Schaumstofffilter.

8

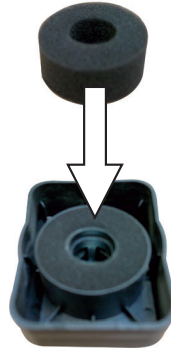

9

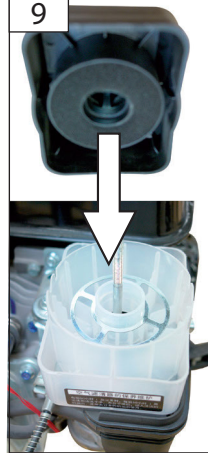

10

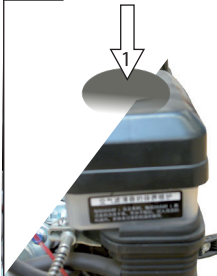

11





Technische Daten

Gartenfräse	GF 420-4.1
Artikel-Nr.	95457
Hubraum	212 ccm
Max. Leistung	4,1 kW/5,5 PS
Kraftstoff	Super/E10
Motorölsorte	10W 40
Arbeitsbreite	420 mm
Anzahl der Messer	12
Ø Messer	350 mm
Messerdrehzahl	188 min ⁻¹
Arbeitstiefe	175-350 mm
Gewicht Netto/Brutto	74 kg / 82 kg
Geräuschangaben	
Schalldruckpegel L _{PA(1)}	84,3 dB(A)
Gemessener Schalleistungspegel L _{WA(1)}	99,8 dB (A)
Garantierter Schalleistungspegel L _{WA(1)}	102 dB (A)
Gemessen nach ¹⁾ prEN 1553:1996; Unsicherheit K =3,0 dB (A); Gehörschutz tragen!	
Vibrationsangaben	
Schwingungsgesamtwerte (Vektorsumme dreier Richtungen) ermittelt entsprechend EN 1033:1995	
Schwingungsemissionswert a _{hw}	7,48 m/s ²
Unsicherheit K = 1,5 m/s ²	

WARNING: Der tatsächliche Schwingungsemissionswert kann sich je nach Art und Weise der Anwendung vom angegebenen Wert unterscheiden. Der Schwingungspegel kann für den Vergleich von Elektrowerkzeugen miteinander verwendet werden. Für eine genaue Abschätzung der Schwingungsbelastung sollten auch die Zeiten berücksichtigt werden, in denen das Gerät abgeschaltet ist oder zwar läuft, aber nicht tatsächlich im Einsatz ist. Dies kann die Schwingungsbelastung über den gesamten Arbeitszeitraum deutlich reduzieren. Legen Sie zusätzliche Sicherheitsmaßnahmen zum Schutz des Bedieners vor der Wirkung von Schwingungen fest wie zum Beispiel: Wartung von Elektrowerkzeug und Einsatzwerkzeugen, Warmhalten der Hände, Organisation der Arbeitsabläufe.



Benutzen Sie das Gerät erst nachdem Sie die Bedienungsanleitung aufmerksam gelesen haben.

Sie sich mit den Gebrauchsanweisungen vertraut. Beachten Sie alle in der Anleitung aufgeführten Sicherheitshinweise. Verhalten Sie sich verantwortungsvoll gegenüber anderen Personen. Der Bediener ist verantwortlich für Unfälle oder Gefahren gegenüber Dritten.

Falls über den Anschluss und die Bedienung des Gerätes Zweifel entstehen sollten, wenden Sie sich an den Kundendienst.

Das Gerät darf nur von Personen betrieben werden, die das 16. Lebensjahr vollendet haben. Eine Ausnahme

stellt die Benutzung als Jugendlicher dar, wenn die Benutzung im Zuge einer Berufsausbildung zur Erreichung der Fertigkeit unter Aufsicht eines Ausbilders erfolgt.

Dieses Gerät ist nicht dafür bestimmt, durch Personen (einschließlich Kinder) mit eingeschränkten physischen, sensorischen oder geistigen Fähigkeiten oder mangels Erfahrung/ oder mangels Wissen benutzt zu werden.

Kinder sollten beaufsichtigt werden, damit sie nicht mit dem Gerät spielen.

Bestimmungsgemäße Verwendung

Für Bodenaufbereitung kleiner bis mittlerer Flächen. Zur Einarbeitung von Mulch, Torf, Sand, Dünger oder Kompost.

Dieses Gerät darf nur wie angegeben bestimmungsgemäß verwendet werden. Bei Nichtbeachtung der Bestimmungen, aus den allgemein gültigen Vorschriften sowie den Bestimmungen aus dieser Anleitung, kann der Hersteller für Schäden nicht verantwortlich gemacht werden.

Restrisiken

Auch bei richtiger Verwendung und Einhaltung aller Sicherheitsbestimmungen, können noch Restrisiken bestehen.

Die rotierenden Messer können zu schweren Schnittverletzungen bzw. schweren Körperteilen führen.

Niemals bei laufendem Gerät unter das Gehäuse fassen. Schutzhandschuhe tragen! Sicherheitsschuhe mit Schnitenschutz, griffiger Sohle und Stahlkappe tragen!

Herausgeschleuderte Steine oder Erde können zu Verletzungen führen.

Zu bearbeitende Flächen im Vorfeld nach Fremdkörpern absuchen. Während der Arbeit eine Schutzbrille tragen.

⚠ Mangelhafte Beleuchtung/ nichtstellmäßiges Licht kann ein hohes Sicherheitsrisiko darstellen.

Sorgen Sie bei der Arbeit mit dem Gerät immer für ausreichende Beleuchtung bzw. gutes Lichtverhältnis.

⚠ Gehörschädigungen

Längerer Aufenthalt in unmittelbarer Nähe des laufenden Geräts kann zu Gehörschädigungen führen. Gehörschutz tragen!

⚠ Gesundheitsschäden, die aus Hand-Arm-Schwingungen resultieren, falls das Gerät über längeren Zeitraum verwendet wird oder nicht

Maßnahmen gegen Gefährdung und Bewandeln

⚠ Schädigung durch Erfassen / Aufwickeln Die rotierenden Messer können das Besondere Schnüre oder Kleidung erfassen und aufwickeln bzw. durchtrennen.

Während der Arbeit immer genügend Abstand zum Kabel am Boden halten und nicht überfahren. Zu bearbeitende Flächen absuchen vor dem Einsatz geeignete Kleidung. Tragen Sie keine weite Kleidung oder Schmuck. Halten Sie Haare, Kleidung und Handschuhe fern von sich bewegenden Teilen.

Verhalten im Notfall

Leiten Sie die der Verletzung entsprechend notwendigen Erste Hilfe Maßnahmen ein und fordern Sie schnellst möglich qualifizierte ärztliche Hilfe an. Bewahren Sie den Verletzten vor weiteren Schädigungen und stellen Sie diesen ruhig. Wenn Sie Hilfe anfordern, machen Sie folgende Angaben:

1. Ort des Unfalls,
2. Art des Unfalls,
3. Zahl der Verletzten,
4. Art der Verletzungen

Symbole



Warnung / Achtung!



Zur Verringerung eines Verletzungsrisikos Betriebsanleitung lesen.



Schutzbrille tragen!
Gehörschutz tragen!



Schutzhandschuhe tragen!



Sicherheitsschuhe mit Schnitenschutz, griffiger Sohle und Stahlkappe tragen!



Langsam



Vor Wartungs- und Reparaturarbeiten Zündkerzenstecker ziehen!



Warnung vor wegschleudernden Teilen



Warnung vor scharfen Messern. Hände und Füße fernhalten. Die Messer laufen auch nach dem Ausschalten noch kurz nach.



Halten Sie in der Nähe stehende Personen auf sicheren Abstand zur Maschine (mindestens 15m)



Warnung vor Schnittverletzungen



Warnung vor Einzugsgefahr



Verletzungsgefahr! Hände und Füße fernhalten.



Vor Wartungs- und Reparaturarbeiten Zündkerzenstecker ziehen!



Vor allen Arbeiten am Gerät Motor ausschalten.



Weisen Sie Kinder und unbefugte Personen an sich stets von dem Gerät fern zu halten.



Vor Nässe schützen. Die Maschine nicht dem Regen aussetzen.



Nicht in den Gefahrenbereich der laufenden Messer greifen!



CE Konformitätszeichen

DE



Garantierter Schalleistungspegel L_{WA}

Sicherheitshinweise

⚠️ Warnung

Lesen Sie alle Sicherheitshinweise und

Warnhinweise bei der Einhaltung der Sicherheitshinweise und Anweisungen können elektrischen Schlag, Brand und/oder schwere Verletzungen verursachen. **Bewahren Sie alle Sicherheitshinweise und Anweisungen für die Zukunft auf.**

Halten Sie Kinder und andere Personen sowie Tiere während der Benutzung des Geräts fern. Der Mindest-Sicherheitsabstand beträgt 5 m.

Tragen Sie persönliche Schutzausrüstung.

Tragen Sie geeignete Arbeitskleidung wie festes Schuhwerk mit rutschfester Sohle, eine robuste, lange Hose, Handschuhe, eine Schutzbrille und Gehörschutz!

Tragen Sie Schutzhandschuhe, wenn dies notwendig ist.

Benutzen Sie das Gerät nur bei Tageslicht oder in gut beleuchteter Umgebung.

Das Gerät muss vor dem Gebrauch sorgfältig überprüft werden. Arbeiten Sie ausschließlich mit Geräten, die in einwandfreiem Zustand sind. Sollten Sie einen Defekt an dem Gerät bemerken, der möglicherweise eine Gefahr für den Bediener darstellen kann, betreiben Sie das Gerät erst nachdem der Defekt beseitigt wurde.

Überprüfen Sie sorgfältig das Gelände, auf dem die Maschine eingesetzt wird, und entfernen Sie alle Gegenstände, die erfasst und weggeschleudert werden können.

Seien Sie aufmerksam, achten Sie darauf, was Sie tun, und gehen Sie mit Vernunft an die Arbeit mit einem Elektrowerkzeug. Benutzen Sie kein Elektrowerkzeug, wenn Sie müde sind oder unter dem Einfluss von Drogen, Alkohol oder Medikamenten stehen.

Niemals bei laufendem Gerät unter das Gehäuse fassen. Halten Sie immer Abstand zur Auswurföffnung.

Vermeiden Sie ein versehentliches Starten. Befinden Sie sich immer in der Startstellung, wenn Sie das Starterseil ziehen.

⚠️ Kraftstoff ist leicht entflammbar.

Bewahren Sie Kraftstoff nur in dafür zugelassenen Behältern auf.

Maschine nur im Freien und nicht in der Nähe von offenen Flammen bzw. brennenden Zigaretten tanken.

Tanken Sie vor dem Starten der Maschine. Während der Motor läuft oder noch heiß ist, darf nicht nachgetankt werden oder der Tankdeckel geöffnet werden.

Achten Sie darauf, dass kein Kraftstoff verschüttet wird. Falls Kraftstoff übergelaufen ist, darf der Motor nicht gestartet werden. Entfernen Sie das Gerät von der verschmutzten Stelle und vermeiden Sie jeglichen Zündversuch, bis sich die Kraftstoffdämpfe verflüchtigt haben.

Vor Erstinbetriebnahme muss der Motor unbedingt mit Motorenöl befüllt werden.

Überprüfen Sie vor jeder Inbetriebnahme den Ölstand. Füllen Sie ggf. Motorenöl nach.

⚠️ Vergiftungsgefahr!

Abgase, Kraftstoffe und Schmierstoffe sind giftig. Das Einatmen von Abgasen kann tödlich sein!

Benutzen Sie das Gerät nur im Außenbereich und niemals in geschlossenen oder schlecht belüfteten Räumen.

Maschine nicht in einem geschlossenen Bereich betreiben, in dem sich gefährliche Kohlenmonoxyd-gase sammeln können.

Führen Sie vor Benutzung stets eine Sichtprüfung durch, um festzustellen, ob das Gerät, insbesondere Schnei-derwerkzeuge, Befestigungsteile oder die gesamte Schneideeinheit, beschädigt ist.

Der Rasenmäher darf nicht betätigt werden, ohne dass entweder die vollständige Grasfangeinrichtung oder die selbstschließende trennende Schutzeinrichtung für die Auswurföffnung angebracht ist.

Überprüfen Sie vor jeder Inbetriebnahme sämtliche Schraub- und Steckverbindungen sowie Schutzeinrichtungen auf Festigkeit und richtigen Sitz und ob alle beweglichen Teile leichtgängig sind.

Überprüfen Sie vor jeder Inbetriebnahme alle Startarretierungen und Tastschalter auf mechanische Funktion.

Es ist strengstens untersagt, die an der Maschine befindlichen Schutzeinrichtungen zu demontieren, abzuändern oder Zweck zu entfernen oder fremde Schutzeinrichtungen anzubringen.

Es ist strengstens untersagt jegliche versiegelten Einrichtungen zur Motordrehzahl zu verändern/ manipulieren.

Das Gerät darf nicht benutzt werden falls es beschädigt ist oder die Sicherheitseinrichtungen defekt sind. Tauschen Sie abgenutzte und beschädigte Teile aus.

Sicherheitshinweise für Gartenfräsen

⚠ Verletzungsgefahr

Achten Sie auf sicheren Stand, besonders an Hängen.

Arbeiten Sie nicht an übermäßig steilen Hängen.

Seien Sie besonders vorsichtig, wenn Sie an Hängen die Fahrrichtung wechseln.

Seien Sie äußerst vorsichtig, wenn Sie wenden und die Maschine zu sich heranziehen.

Gehen Sie! Nicht rennen!

Überprüfen Sie sorgfältig das Gelände, auf dem die Maschine eingesetzt wird, und entfernen Sie alle Gegenstände, die erfasst und weggeschleudert werden können wie z. B. Steine, Äste, Drähte, Lebewesen etc.

Halten Sie Kinder und andere Personen während der Benutzung des Elektrowerkzeugs fern. Der Mindest-Sicherheitsabstand beträgt 15 m.

Die Verwendung der Maschine unter Schlechtwetterbedingungen, insbesondere bei Blitzeis, ist zu vermeiden.

Starten Sie den Motor vorsichtig entsprechend den Herstelleranweisungen und achten Sie auf ausreichenden Abstand der Füße zu dem (den) Werkzeug(en). Führen Sie niemals Hände oder Füße an oder unter sich drehende Teile. Heben oder tragen Sie niemals eine Maschine mit laufendem Motor.

Stellen Sie sicher das sich das Verlängerungskabel stets frei bewegen kann und halten Sie das Verlängerungskabel von der Messereinheit fern. Das Verlängerungskabel darf auf keinen Fall überfahren werden.

Halten Sie den durch das Griffgestänge gegebenen Sicherheitsabstand ein.

Führen Sie das Gerät immer mit beiden Händen am Griffholm.

Stoppen Sie das Gerät und trennen es von der Stromversorgung

- wann immer Sie das Gerät verlassen
- vor dem Entfernen von Blockierungen

- vor Überprüfen, Reinigen oder Arbeiten am Gerät
- nach Kontakt mit einem Fremdkörper, um das Gerät auf Beschädigungen zu überprüfen

Schalten Sie bei Blockierung das Gerät sofort aus und warten Sie bis die Maschine ausgelaufen ist. Entfernen Sie dann den Gegenstand. Für Eingriffe im Messerbereich Schutzhandschuhe tragen

Tragen Sie persönliche Schutzausrüstung. Tragen Sie feste Schuhe und lange Hosen. Betreiben Sie die Maschine nicht barfuß oder mit offenen Sandalen.

Der Ein-/ Ausschalter und der Sicherheitsschalter dürfen nicht arretiert werden.

Alle Schutzbleche und Sicherheitsvorrichtungen müssen für den Betrieb des Gerätes korrekt befestigt sein

Überprüfen Sie vor jeder Benutzung (Sichtprüfung) die Messereinheit und deren Befestigungsmittel auf Beschädigungen. Zur Vermeidung einer Unwucht dürfen abgenutzte oder beschädigte Teile und Befestigungsbolzen nur satzweise ausgetauscht werden.

Das Gerät darf nicht benutzt werden falls es beschädigt ist oder die Sicherheitseinrichtungen defekt sind. Tauschen Sie abgenutzte und beschädigte Teile aus.

Sollte das Gerät unnormal zu vibrieren beginnen, schalten Sie den Motor ab, und suchen Sie sofort nach der Ursache. Vibrationen sind generell eine Warnung vor einer Betriebsstörung.

Warnung! Dieses Elektrowerkzeug erzeugt während des Betriebs ein elektromagnetisches Feld. Dieses Feld kann unter bestimmten Umständen aktive oder passive medizinische Implantate beeinträchtigen. Um die Gefahr von ernsthaften oder tödlichen Verletzungen zu verringern, empfehlen wir Personen mit medizinischen Implantaten Ihren Arzt und den Hersteller vom medizinischen Implantat zu konsultieren, bevor die Maschine bedient wird.

Benutzen Sie das Gerät nicht in der Nähe von entzündbaren Flüssigkeiten oder Gasen. Bei Kurzschluss besteht Brand- und Explosionsgefahr..

WARTUNG

⚠ Gefahr – Rotierende Messer.

Warten Sie, bis alle rotierenden Teile zum Stillstand gekommen sind und sich das Gerät abgekühlt hat.



Fallen Arbeiten am Gerät Motor abstellen und Zündkerzenstecker ziehen. Warten Sie, bis alle rotierenden Teile zum Stillstand gekommen sind und sich das Gerät abgekühlt hat.

Machine, insbesondere Tank- und Motorbereich, stets sauber halten. Grasauswurf und Gehäuse regelmäßig reinigen.

Entfernen Sie regelmässig alle Rasen- und Unkrautreste um ein Überhitzen des Schaftrohrs zu vermeiden. Rasen-/Gras-/Unkrautreste verfangen sich unterhalb des Schutzschildes, dies verhindert eine ausreichende Kühlung des Schaftrohrs. Entfernen Sie die Reste vorsichtig mit einem Schraubenzieher oder einem anderen Werkzeug. Die Brandgefahr auf ein Minimum einzuschränken, die Zylinderrippen häufig mit Pressluft reinigen und den Bereich des Schalldämpfers von Zweigresten, Blättern oder anderen Rückständen befreien.

Um die Brandgefahr möglichst gering zu halten, müssen Motor und Auspuff frei von Gras, Laub und überschüssigem Schmierfett sein.

Gerät, insbesondere Lüftungsschlitze, stets sauber halten. Gerätekörper niemals mit Wasser abspritzen. Kunststoffe nicht mit Lösemittel, entzündlichen oder giftigen Flüssigkeiten reinigen. Zum Reinigen nur ein feuchtes Tuch benutzen.

Behandeln Sie alle beweglichen Teile mit einem umweltfreundlichen Öl.

Reparaturen und Arbeiten, die nicht in dieser Anleitung beschrieben wurden, nur von qualifiziertem Fachpersonal durchführen lassen.

Nur Originalzubehör und Originalersatzteile verwenden.

Nur ein regelmässig gewartetes und gut gepflegtes Gerät kann ein zufriedenstellendes Hilfsmittel sein. Wartungs- und Pflegemängel können zu unvorhersehbaren Unfällen und Verletzungen führen.

Bei Bedarf finden Sie die Ersatzteilliste im Internet unter www.guede.com.

Lagerung

Lagern Sie das Gerät und dessen Zubehör an einem dunklen, trockenen und frostfreien sowie für Kinder unzugänglichem Ort.

Entsorgung

Die Entsorgungshinweise ergeben sich aus den Piktogrammen die auf dem Gerät bzw. der Verpackung aufgebracht sind.

Schadhafte und/oder zu entsorgende Geräte müssen an den dafür vorgesehenen Recycling-Stellen abgegeben werden.

Gewährleistung

Die Gewährleistungszeit beträgt 12 Monate bei gewerblicher Nutzung, 24 Monate für Verbraucher und beginnt mit dem Zeitpunkt des Kaufs des Gerätes.

Die Gewährleistung erstreckt sich ausschließlich auf Mängel, die auf Material- oder Herstellungsfehler zurückzuführen sind. Bei Geltendmachung eines Mangels im Sinne der Gewährleistung ist der original Kaufbeleg mit Verkaufsdatum beizufügen.

Von der Gewährleistung ausgeschlossen sind unsachgemäße Anwendungen, wie z. B. Überlastung des Gerätes, Gewaltanwendung, Beschädigungen durch Fremdeinwirkung oder durch Fremdkörper. Nichtbeachtung

der Betriebsanleitung und normaler Verschleiß sind ebenfalls von der Gewährleistung ausgeschlossen..

Wichtige Kundeninformation

Bitte beachten Sie, dass eine Rücksendung innerhalb oder auch außerhalb der Gewährleistungszeit grundsätzlich in der Originalverpackung erfolgen sollte. Durch diese Maßnahme werden unnötige Transportschäden und deren oft strittige Regelung wirkungsvoll vermieden. Nur im Originalkarton ist Ihr Gerät optimal geschützt und somit eine reibungslose Bearbeitung gesichert.

Service

Sie haben technische Fragen? Eine Reklamation? Benötigen Ersatzteile oder eine Betriebsanleitung? Auf der Homepage der Firma Güde GmbH & Co. KG (www.guede.com) im Bereich Service helfen wir Ihnen schnell und unbürokratisch weiter. Bitte helfen Sie uns Ihnen zu helfen. Um Ihr Gerät im Reklamationsfall identifizieren zu können benötigen wir die Seriennummer sowie Artikelnummer und Baujahr. Alle diese Daten finden Sie auf dem Typenschild.

Tel.: +49 (0) 79 04 / 700-360

Fax: +49 (0) 79 04 / 700-51999

E-Mail: support@ts.guede.com

Fehlerbehebung

Störung	Mögliche Ursache	Empfohlene Abhilfe
Der Motor startet nicht	<ol style="list-style-type: none"> 1. Tank leer 2. Luftfilter verschmutzt 3. Kein Zündfunke 4. Motor abgesoffen 	<ol style="list-style-type: none"> 1. Volltanken; prüfen, ob der Vergaser Kraftstoff enthält; Tankentlüftung prüfen und Loch im Tankdeckel mit Nadel durchstoßen 2. Luftfilter reinigen 3. Zündkerze reinigen, evtl. neue einsetzen; Zündkabel prüfen; Zündanlage von Service-Stelle prüfen lassen 4. Zündkerze herausdrehen, reinigen und trocknen; Starterseil bei heraus geschraubter Zündkerze mehrmals ziehen
Motor hat Aussetzer	<ol style="list-style-type: none"> 1. Zündkabel ist locker 2. Kraftstoffleitung ist verstopft oder schlechter Kraftstoff 3. Belüftung im Kraftstoffbehälterdeckel ist verstopft 4. Es befindet sich Wasser oder Schmutz in der Kraftstoffanlage 5. Luftfilter ist verschmutzt 	<ol style="list-style-type: none"> 1. Kerzenstecker fest auf die Zündkerze stecken 2. Kraftstoffleitung reinigen, frischen Kraftstoff verwenden 3. Kraftstoffbehälterdeckel austauschen 4. Kraftstoff ablassen und sauberen, frischen Kraftstoff tanken 5. Luftfilter reinigen
Motor geht im Leerlauf häufig aus	<ol style="list-style-type: none"> 1. Zündabstand zu groß, Zündkerze defekt 2. Vergaser nicht korrekt eingestellt 3. Luftfilter verschmutzt 	<ol style="list-style-type: none"> 1. Zündkerze einstellen oder erneuern 2. Vergaser einstellen 3. Luftfilter reinigen
Antrieb funktioniert nicht richtig	<ol style="list-style-type: none"> 1. Seilspannung des Antriebshebels prüfen 2. Antrieb geht nicht 	<ol style="list-style-type: none"> 1. Seilspannung gegebenenfalls nachstellen. 2. Gerät von einer Service-Stelle prüfen lassen.
Ungewöhnliche Vibrationen	<ol style="list-style-type: none"> 1. Messer beschädigt oder stumpf. 2. Befestigungsschrauben sind locker 	<ol style="list-style-type: none"> 1. Tauschen Sie die Messer aus. 2. Befestigungsschrauben festziehen
Unbefriedigendes Ergebnis	Stumpfe Messer	Tauschen Sie die Messer aus.

Inspektions- und Wartungsplan

 Bei Nichteinhaltung des Wartungsplanes kann es zu Schäden am Motor kommen!

Regelmäßige Wartungsperiode		Vor jeder Inbetriebnahme	Nach 1 Monat	Nach 3 Monaten	Nach 6 Monaten	Nach 12 Monaten	Nach 24 Monaten
			5 Betriebsstunden	25 Betriebsstunden	50 Betriebsstunden	100 Betriebsstunden	250 Betriebsstunden
Motoröl (10W-40)	Kontrollieren	✓					
	Ersetzen		✓		✓		
Luftfilter	Kontrollieren	✓					
	Ersetzen				✓		
Zündkerze	Kontrollieren					✓	
	Reinigen						
	Ersetzen						✓

Die entsprechende Wartung im angegebenen Monat oder nach dem Ablauf der vorgegebenen Betriebsstunden durchführen - je nachdem, was früher eintritt.

DE



GF 420 - 4.1

95457





ОБХВАТ НА ДОСТАВКАТА



> 20 кг



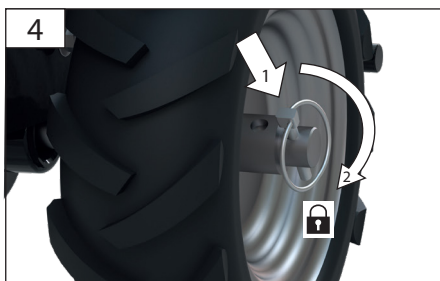
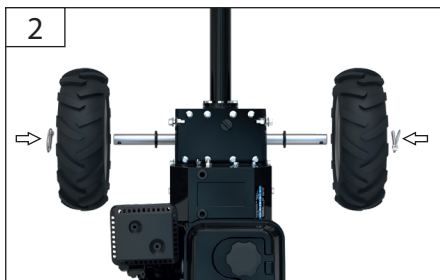

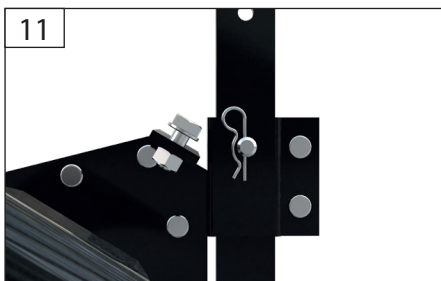
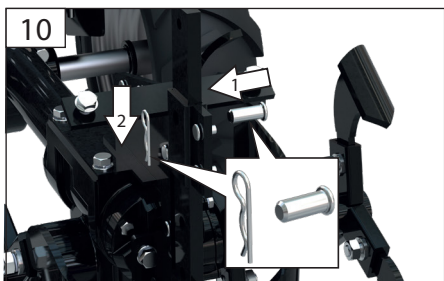
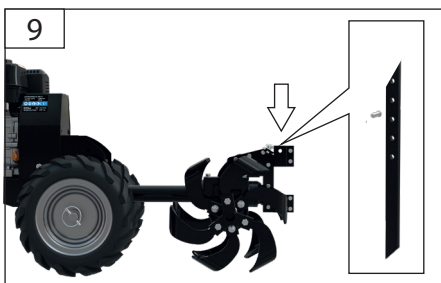
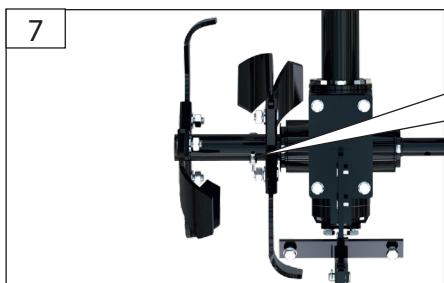
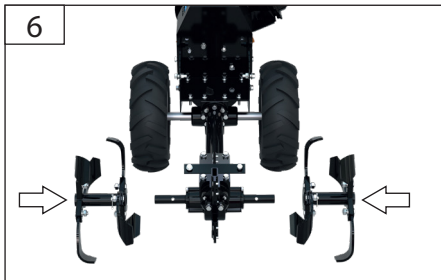

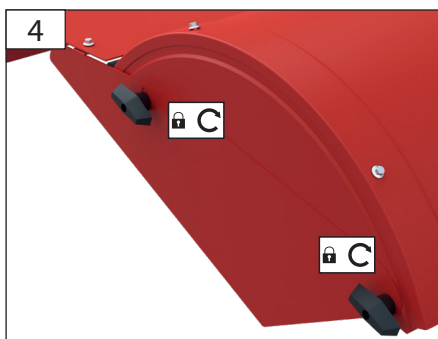
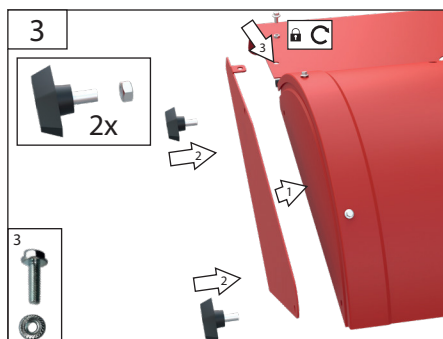
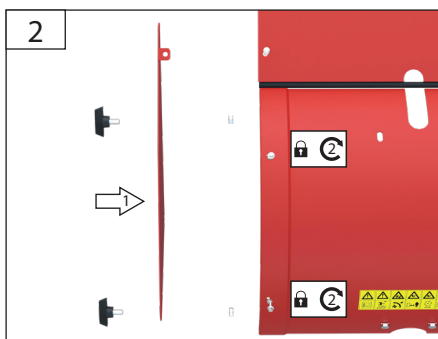
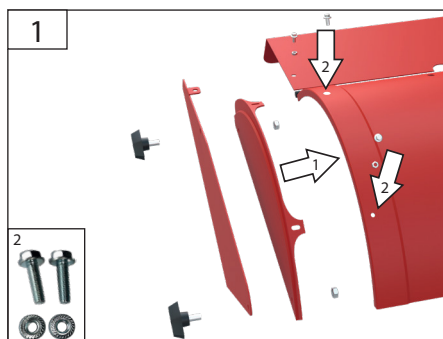
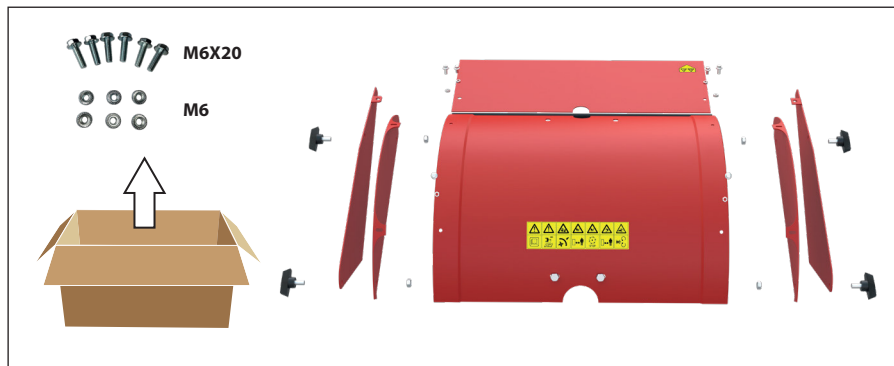

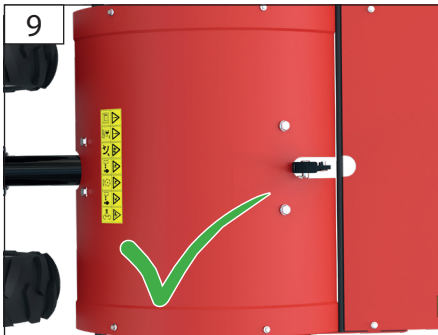
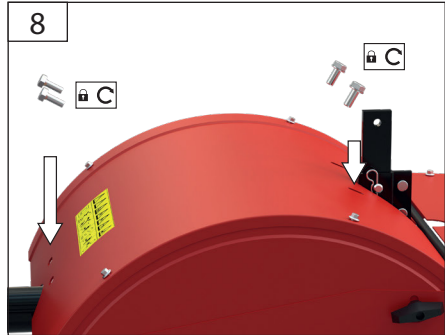
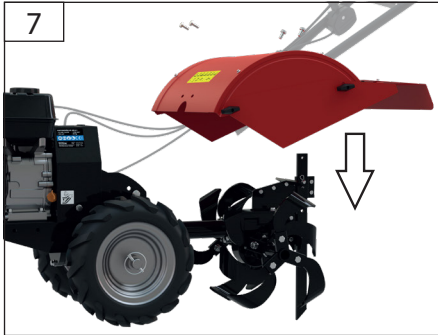
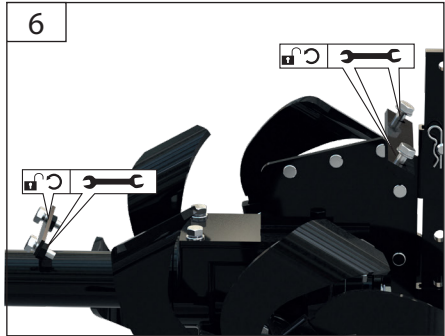
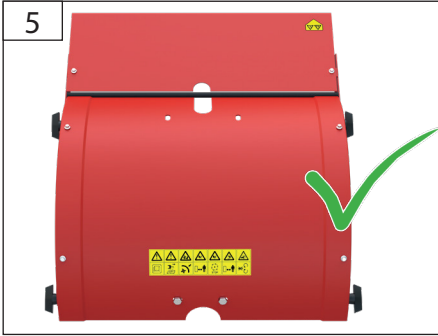

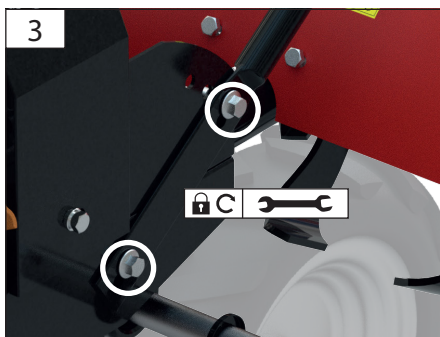
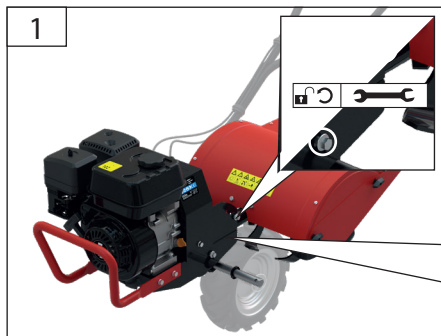

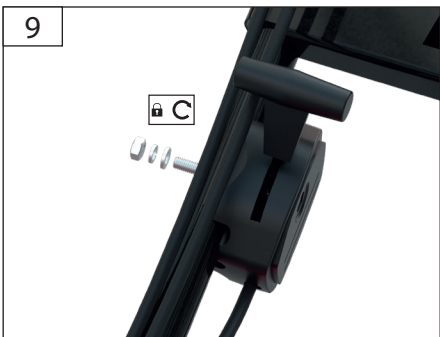
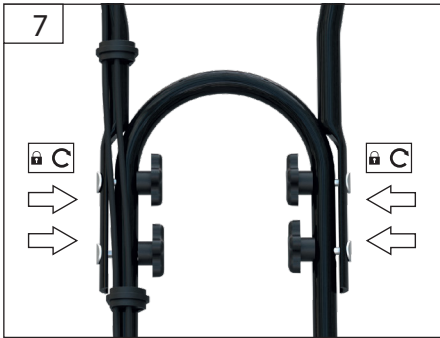
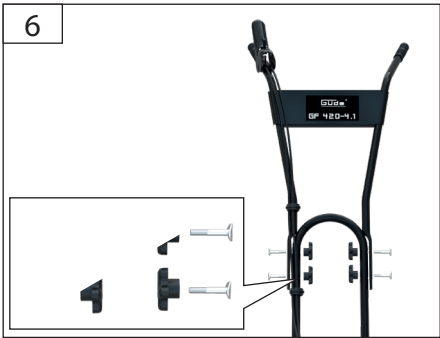

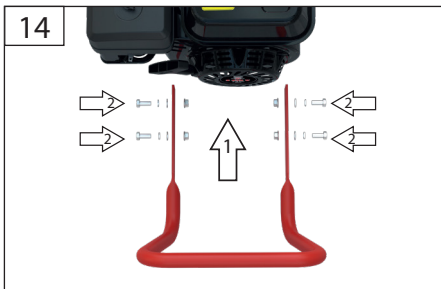
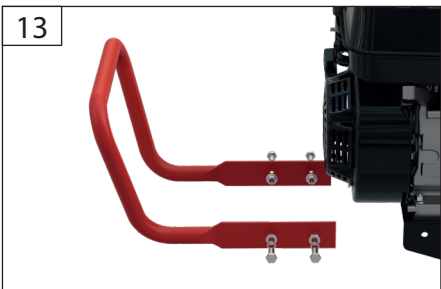
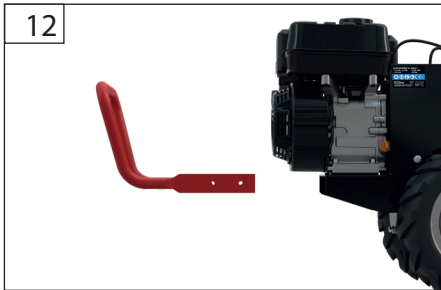
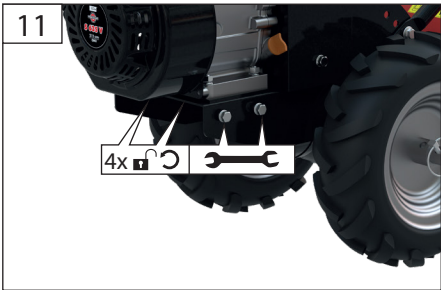



10W-40

DE Преди първото пускане в експлоатация

двигателят задължително трябва да се напълни с моторно масло. Преди всяко пускане проверявайте нивото на маслото.

1



2

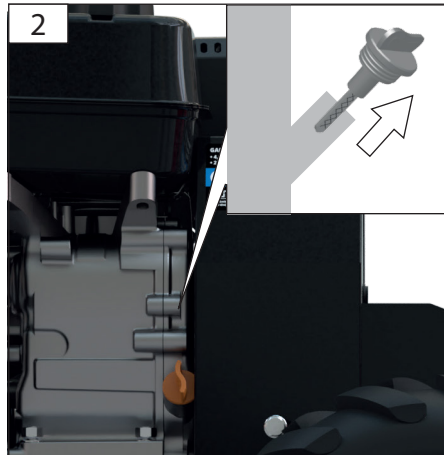



3

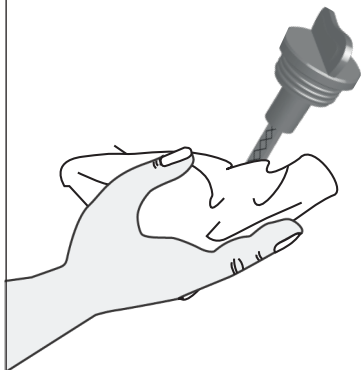

4

Тест

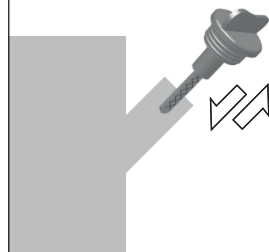
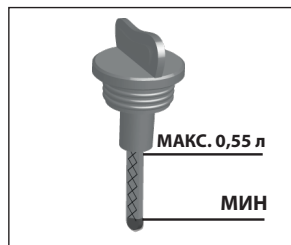

5

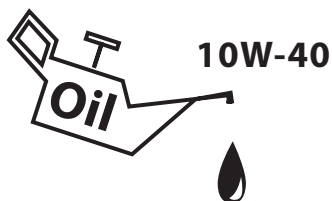

6

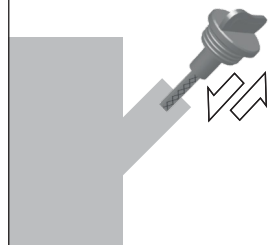
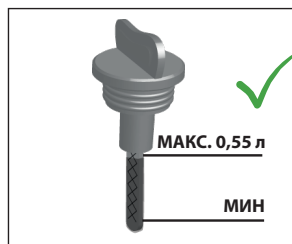





DE Поради осигуряване на качеството

всяко устройство се подлага на пробен пуск и се пълни с моторно масло.

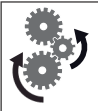
Преди транспортиране маслото се източва отново, но е възможно по щеката да има остатъци от моторно масло. Моля, въпреки това проверете старателно нивото на маслото и долейте моторно масло. 7+8



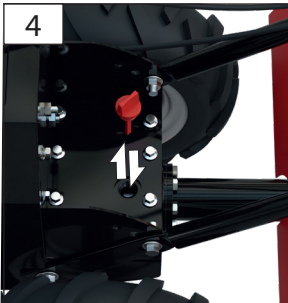
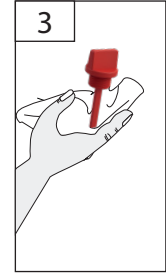
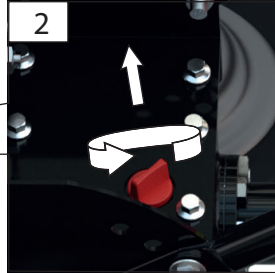

S5 DCT 11





МАКС
МИН



МАКС 0,4 л
МИН

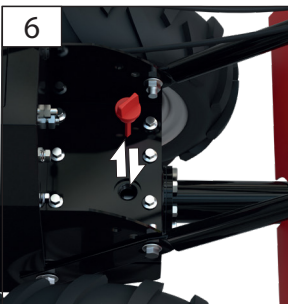
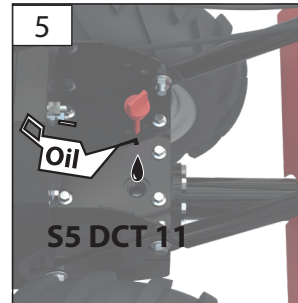

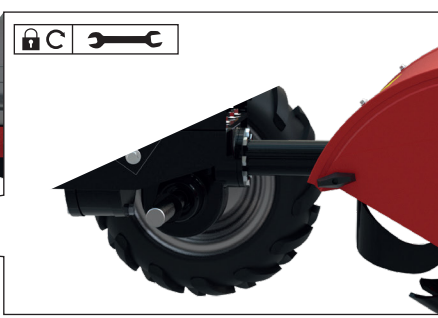
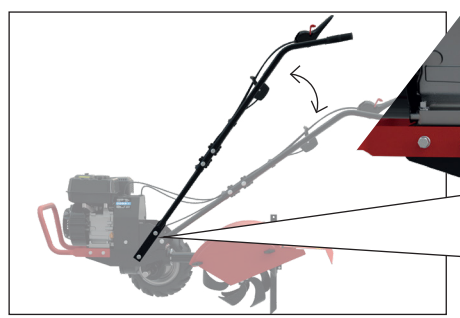
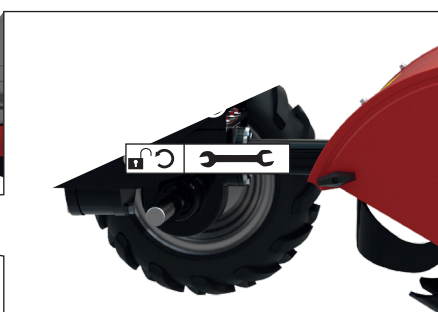
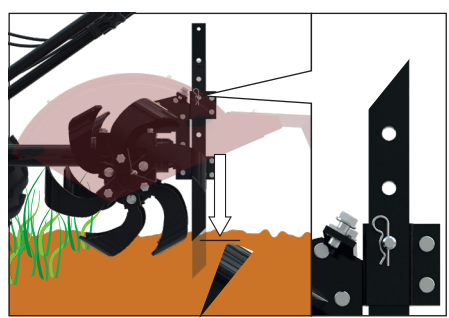
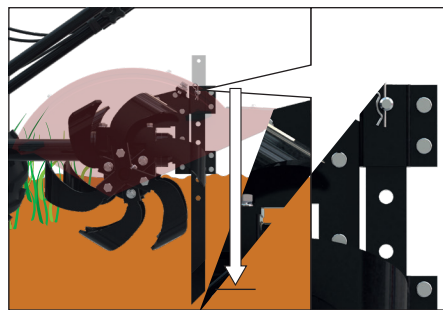

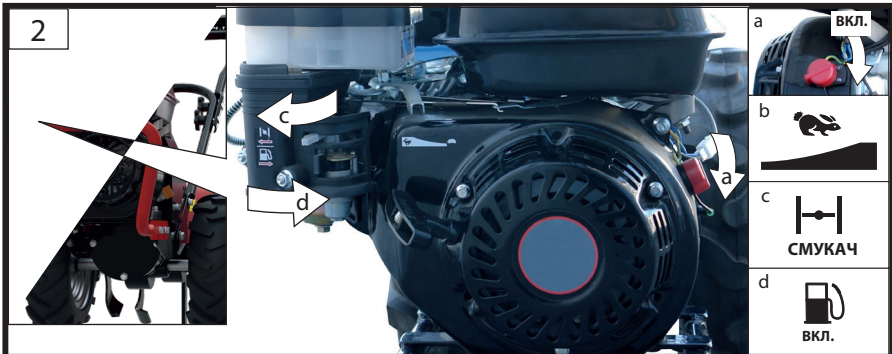
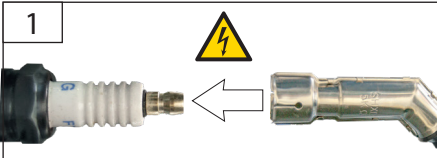
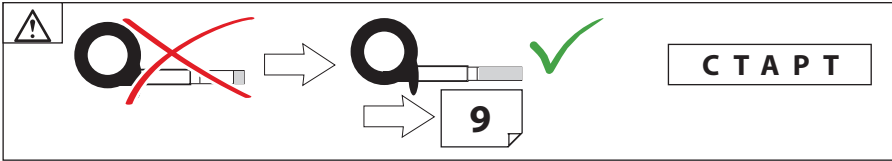

DE Дроселът трябва да се отваря само когато двигателят е студен.

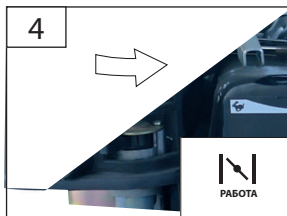
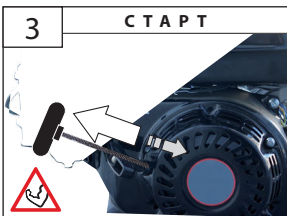



СТОП

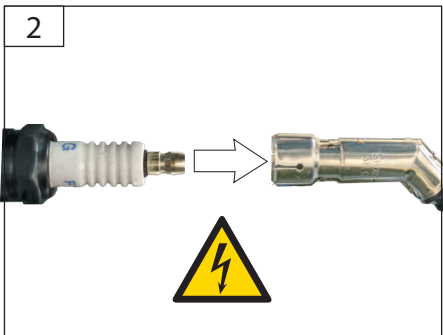
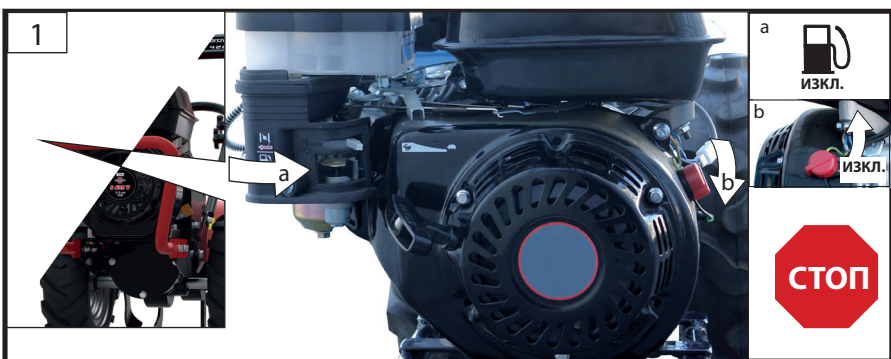



1



2a



2b

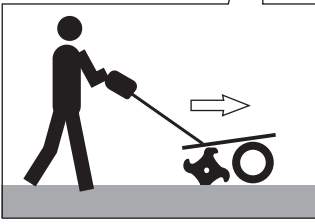

3



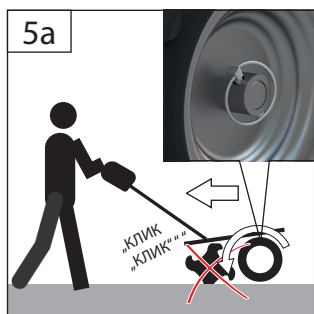
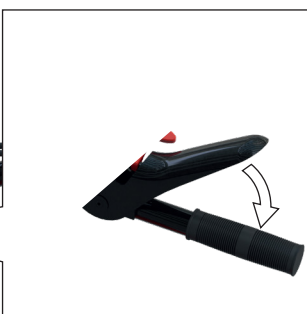
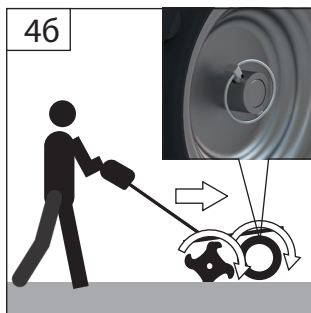
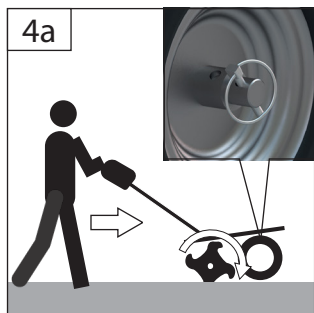
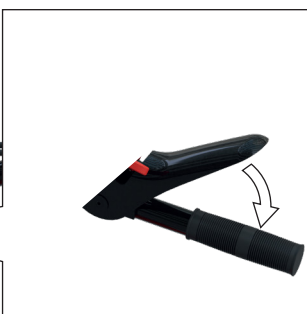
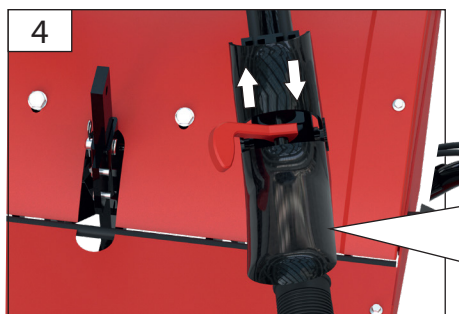

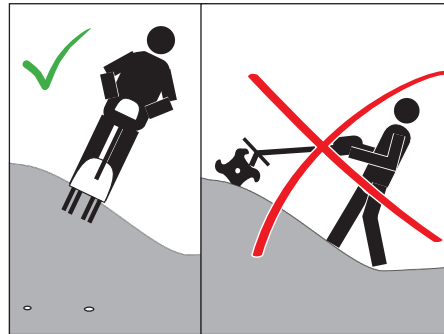
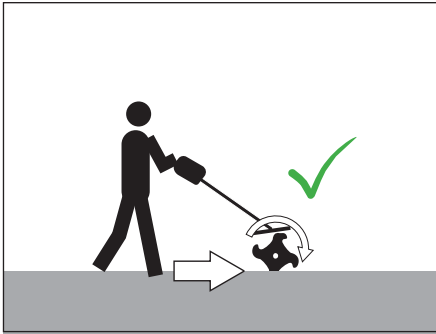

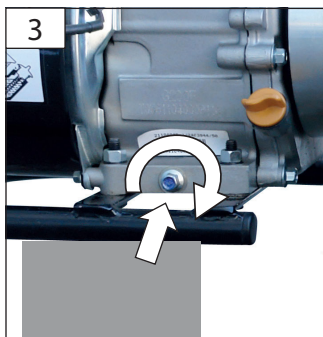
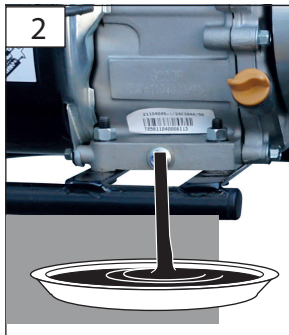
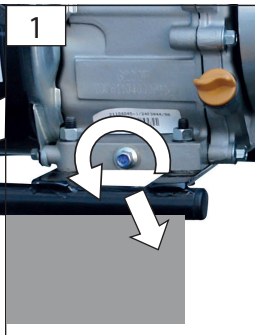
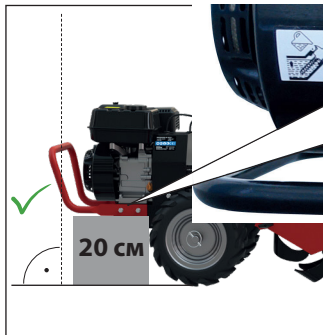
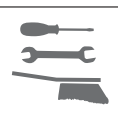

4

DE Долейте/проверете нивото на маслото!

➔

9

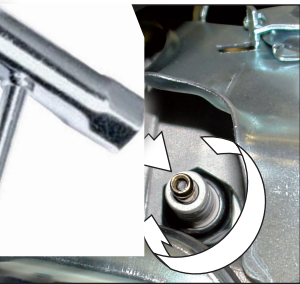
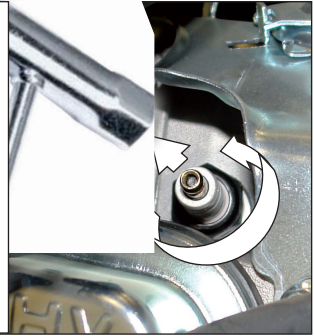
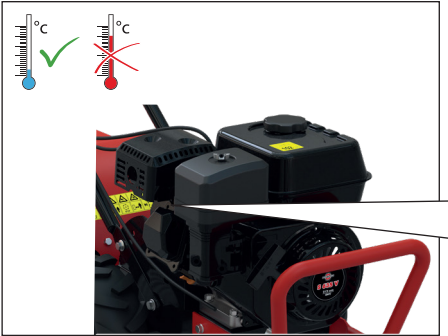

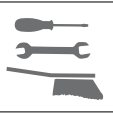

7

СЪВЕТ



СЪВЕТ: Капнете няколко капки масло върху дунареновия филтър.

8

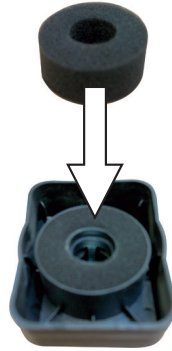

9

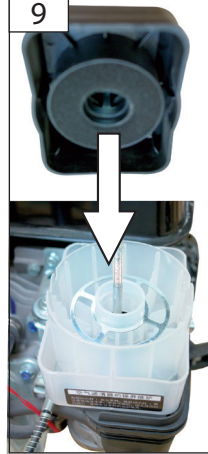

10

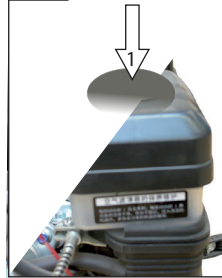

11

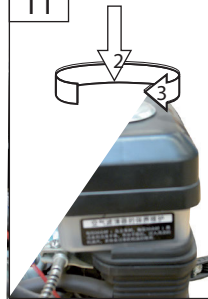



1



2



3



Технически данни

Градинска фреза	GF 420-4.1
Арт. №	95457
Работен обем	212 ccm
Макс. мощност	4,1 kW/5,5 PS
Гориво	Сунеп/E10
Тип моторно масло	10W 40
Работна ширина	420 mm
Брой ножове	12
Ø на ножовете	350 mm
Обороти на ножовете	188 min ⁻¹
Работна дълбочина	175-350 mm
Тегло нето/бруто	74 kg / 82 kg
Данни за шум	
Ниво на звуково налягане L _{p(A1)}	84,3 dB(A)
Измерено ниво на звукова мощност L _{WA 1)}	99,8 dB (A)
Гарантирано ниво на звукова мощност L _{WA 1)}	102 dB (A)
Измерено съгласно 1) prEN 1553:1996; Неопределеност K = 3,0 dB (A); Носете защита за слуха!	
Данни за вибрации	
Общи стойности на вибрациите (векторна сума по три направления), определени съгласно EN 1033:1995	
Стойност на вибрационните емисии a _{hw}	7,48 m/s ²
Неопределеност K = 1,5 m/s ²	

ПРЕДУПРЕЖДЕНИЕ: Действителната стойност на емисиите на вибрации може да се различава от посочената в зависимост от начина на използване. Нивото на вибрации може да се използва за сравнение между електроинструменти. За по-точна оценка на вибрационното натоварване следва да се вземат предвид и периодите, в които уредът е изключен или работи, но реално не се използва. Това може значително да намали вибрационното натоварване за целия работен период.

Въведете допълнителни мерки за безопасност за защита на оператора от въздействието на вибрациите, например: поддръжка на електроинструмента и работните приставки, поддръжане на ръцете топли, организация на работните процеси.



Използвайте уреда едва след като внимателно прочетете и разберете инструкциите за употреба за управление и с правилната употреба на уреда. Спазвайте всички указания за безопасност, посочени в ръководството. Бъдете отговорни към другите хора.

Операторът носи отговорност за инциденти или опасности за трети лица.

Ако имате съмнения относно свързването и работата с уреда, обърнете се към сервизното обслужване.

Уредът може да се използва само от лица, навършили 16 години. Изключения

е използването от непълнолетни в рамките на професионално обучение за придобиване на умения, под надзора на инструктор.

Този уред не е предназначен за използване от лица (включително деца) с ограничени физически, сетивни или умствени способности или при липса на опит и/или знания.

Децата трябва да бъдат под надзор, за да не си играят с уреда.

Употреба по предназначение

За обработка на почвата на малки до средни площи. За вработване на мулч, торф, пясък, тор или компост.

Този уред трябва да се използва само по предназначение, както е описано. При неспазване на указанията, общовалидните правила и разпоредбите в това ръководство, производителят не може да носи отговорност за причинени щети.

Остатъчни рискове

Дори при правилна употреба и спазване на всички мерки за безопасност е възможно да останат остатъчни рискове.

Въртящите се ножове могат да причинят тежки порезни наранявания или отравя.

Никога не бъркайте под корпуса, докато уредът работи. Носете защитни ръкавици! Носете предпазни обувки със защита от срязване, грайферна подметка и стоманено бомбе!

Изхвърлени камъни или пръст могат да причинят наранявания.

Преди работа проверете обработваните площи за чужди предмети. По време на работа носете защитни очила.

⚠ Недостатъчно осветление / виждате ли в тъмнота? - висок риск за безопасността.

При работа с уреда винаги осигурявайте достатъчно осветление, т.е. добри светлинни усло

⚠ Увреждане на слуха

Продължителният престой в непосредствена близост до работещия уред може да доведе до увреждане на слуха. Носете антифони!

⚠ Рискове за здравето вследствие на вибрации ръка-рамо, ако уредът се използва продължително време или не се води и поддържа правилно.

Правете редовни почивки. Ограничете натоварването за деня.

⚠ Опасност от захващане / увиване

Въртящите се ножове могат да захванат бързо дрехите или бижута и да ги увият или прережат. По време на работа винаги дръжте достатъчно разстояние от кабела на земята и не минавайте върху него. ЗЗu площите за обработка предварително диверсезае изходящо облекло. Не носете широки дрехи или бижута. Дръжте косата, дрехите и ръкавиците далеч от движещите се части.

Действия при аварийна ситуация

Предприемете необходимите мерки за първа помощ според вида на нараняването и възможно най-бързо потърсете квалифицирана медицинска помощ. Предпазете пострадалия от допълнителни увреждания и го успокойте. При подаване на сигнал за помощ посочете следното:

1. Място на инцидента,
2. Вид на инцидента,
3. Брой пострадали,
4. Вид на нараняванията

Символи



Предупреждение / Внимание!



За намаляване на риска от нараняване прочетете ръководството за експлоатация.



Носете защитни очила!
Носете защита за слуха!



Носете защитни ръкавици!



Носете предпазни обувки със защита от срязване, противоплъзгаща подметка и стоманено бомбе!



Бавно



Преди дейности по поддръжка и ремонт извадете лулата на запалителната свещ!



Предупреждение за изхвърчащи части



Предупреждение за остри ножове. Дръжте ръцете и краката на разстояние. Ножовете продължават да се въртят още кратко време и след изключване.



Дръжте хората в близост на безопасно разстояние от машината (най-малко 15 m)



Предупреждение за порязвания



Предупреждение за опасност от захващане



Опасност от нараняване! Дръжте ръцете и краката на разстояние.



Преди дейности по поддръжка и ремонт извадете лулата на запалителната свещ!



Преди всякаква работа по уреда изключете двигателя.



Укажете на децата и неупълномощените лица винаги да стоят далеч от уреда.



Пазете от влага.
Не излагайте машината на дъжд.



Не посягайте в опасната зона на работещите ножове!



Знак за съответствие CE



Гарантирано ниво на звукова мощност L_{WA}

Указания за безопасност

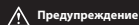

Предупреждение

Прочетете всички указания за безопасност и инструкции на указанията за безопасност и инструкциите може да доведе до токов удар, пожар и/или тежки наранявания. **Запазете всички указания за безопасност и инструкции за бъдещ спазване.**

Дръжте деца, други хора и животни на разстояние по време на работа с уреда. Минималната безопасна дистанция е 5 м.

Носете лични предпазни средства.

Носете подходящо работно облекло – стабилни обувки с противоплъзгаща подметка, здрав дълъг панталон, ръкавици, предпазни очила и защита за слуха!

Носете защитни ръкавици, когато е необходимо.

Използвайте уреда само при дневна светлина или в добре осветена среда.

Преди употреба уредът трябва да бъде внимателно проверен. Работете само с уреди в изправно състояние. Ако забележите повреда, която може да представлява опасност за оператора, използвайте уреда едва след отстраняване на неизправността.

Огледайте внимателно терена, на който ще се използва машината, и отстранете всички предмети, които могат да бъдат захванати и изхвърлени.

Бъдете нащрек, следете какво правите и работете разумно с електроинструмента. Не използвайте електроинструмент, ако сте уморени или сте под въздействието на наркотици, алкохол или лекарства.

Никога не посягайте под корпуса, когато уредът работи. Винаги стойте на разстояние от отвора за изхвърляне.

Предотвратете неволно стартиране. Винаги заемайте стартовата позиция, когато дърпате стартерното въже.

Горивото е леснозапалимо.

Съхранявайте горивото само в одобрени за целта съдове.

Зареждайте машината с гориво само на открито и далеч от открит пламък и запалени цигари.

Заредете с гориво преди да стартирате машината. Докато двигателят работи или е още горещ, не доливайте гориво и не отваряйте капачката на резервоара.

Внимавайте да не разлеее гориво. Ако гориво се е разлило, двигателят не бива да се стартира. Отдалечете уреда от замърсеното място и не правете опити за запалване, докато парите от горивото не се разсеят.

Преди първото пускане двигателят задължително трябва да се напълни с моторно масло.

Преди всяко пускане проверявайте нивото на маслото. При нужда долейте моторно масло.

Опасност от отравяне!

Изгорелите газове, горивата и смазочните материали са токсични. Вдишването на изгорели газове може да бъде смъртоносно!

Използвайте уреда само на открито и никога в затворени или слабо проветрени помещения.

Не използвайте машината в затворени пространства, където могат да се натрупат опасни газове от въглероден оксид.

Преди употреба винаги правете визуална проверка, за да установите дали уредът — особено режещите инструменти, крепежните елементи или целият режещ модул — не е повреден.

Косачката не трябва да се използва, ако не е монтирано или пълното устройство за събиране на трева, или самозатварящото се отделящо защитно устройство за отвора за изхвърляне.

⚠ Преди всяко пускане проверявайте всички винтови и щепселни съединения, както и предпазните устройства – да са здраво затегнати и правилно поставени, и дали всички подвижни части се движат свободно.

⚠ Преди всяко пускане проверявайте всички блокировки за стартиране и бутонни превключватели за изправка

⚠ Друго е забранено да демонтирате, променят или използвате не по предназначение предпазните устройства на машината, както и да монтирате чужди/несъвместими предпазни устройства.

⚠ Друго е забранено да променят или манипулирате каквито и да било запечатани устройства за регулиране на оборотите на двигателя.

⚠ Уредът не трябва да се използва, ако е повреден или ако предпазните устройства са неизправни. Подменяйте износените и повредени части.

Указания за безопасност за градински фрези

⚠ Опасност от нараняване

Осигурете си стабилна опора, особено по склонове.

Не работете по прекалено стръмни склонове. Бъдете особено внимателни, когато сменят посоката на движение по склон.

Бъдете изключително внимателни при завиване и когато придърпвате машината към себе си.

Ходете! Не тичайте!

Проверете внимателно терена, на който ще работи машината, и отстранете всички предмети, които могат да бъдат захванати и извърлени — напр. камъни, клони, тел, живи същества и др.

Дръжте деца и други хора на разстояние по време на работа с електроинструмента. Минималната безопасна дистанция е 15 m.

Избягвайте използването на машината при лоши метеорологични усло-вия, особено при риск от мъгли.

Стартирайте двигателя внимателно според указанията на производителя и осигурете достатъчно разстояние между краката и работния(те) инструмент(и). Никога не поставяйте ръце или крака към или под въртящи се части. Никога не поддигайте и не пренасяйте машина с работещ двигател.

Уверете се, че удължителният кабел винаги може да се движи свободно, и го дръжте далеч от ножовия модул. В никакъв случай не преминавайте върху удължителния кабел.

Спазвайте безопасната дистанция, осигурена от кормилната рамка.

Винаги водете уреда, като държите ръкохватката с две ръце.

Спрете уреда и го изключете от електрозахранването

- винаги когато оставяте уреда без надзор
- преди отстраняване на блокирания

- преди проверка, почистване или работа по уреда
- след контакт с чужд предмет, за да проверите уреда за повреди

При блокиране незабавно изключете уреда и изчакайте машината да спре напълно. След това отстранете предмета. При работа в зоната на ножовете носете защитни ръкавици

Носете лични предпазни средства. Носете здрави обувки и дълги панталони. Не работете с машината боси или с отворени сандали.

Бутонът за Вкл./Изкл. и предпазният превключвател не трябва да се фиксират.

Всички предпазни щитове и защитни устройства трябва да са правилно закрепени за работа с уреда

⚠ Преди всяка употреба (визуална проверка) огледайте ножовия модул и неговите крепежни елементи за повреди. За да се избегне дисбаланс, износените или повредени части и закрепващите болтове се подменят само комплектно.

⚠ Уредът не трябва да се използва, ако е повреден или ако защитните устройства са неизправни. Подменете износените и повредени части.

Ако уредът започне да вибрира необичайно, изключете двигателя и незабавно потърсете причината. Вибрациите по принцип са предупреждение за неизправност при работа.

Внимание! Този електроинструмент създава електромагнитно поле по време на работа. При определени условия това поле може да повлияе на активни или пасивни медицински импланти. За да се намали рискът от сериозни или фатални наранявания, препоръчваме на хора с медицински импланти да се консултират с лекаря си и с производителя на импланта, преди машината да бъде използвана.

Не използвайте уреда в близост до запалими течности или газове. При късо съединение съществува опасност от пожар и експлозия..

ПОДДРЪЖКА

⚠ Опасност – въртящи се ножове.

Изчакайте всички въртящи се части да спрат напълно и уредът да се охлади.



⚠ Преди всякакви дейности по уреда изключете двигателя и извадете щекера на запалителната свещ. Изчакайте всички въртящи се части да спрат напълно и уредът да се охлади.

Поддържайте машината винаги чиста, особено зоната около резервоара и двигателя. Почиствайте редовно изхвърлянето на тревата и корпуса.

Премахвайте редовно всички остатъци от трева и плевели, за да избегнете прегряване на тръбата на вала. Остатъци от трева/плевели се задържат под предпазния щит и това възпрепятства достатъчното охлаждане на тръбата. Отстранявайте ги внимателно с отвертка или подобен инструмент.

За да сведете риска от пожар до минимум, почиствайте често ребрата на цилиндъра със сгъстен въздух и освобождавайте зоната около заглушителя от клонки, листа и други натрупвания.

За да поддържате риска от пожар възможно най-нисък, двигателят и ауспухът трябва да са чисти от трева, листа и излишна смазка.

Поддържайте уреда, особено вентилационните отвори, винаги чист. Никога не обливайте корпуса с вода. Не почиствайте пластмасовите части с разтворители, запалими или токсични течности. За почистване използвайте само влажна кърпа.

Смазвайте всички подвижни части с

екологично масло.

Ремонти и дейности, които не са описани в това ръководство, възлагайте само на квалифициран сервизен персонал.

Използвайте само оригинални аксесоари и

оригинални резервни части. Редовно и се поддържа добре, може да бъде надежден помощник. Пропуски в поддръжката и грижата могат да доведат до непредвидими инциденти и наранявания.

При нужда списъкът с резервни части е достъпен онлайн на www.guede.com.

Съхранение

Съхранявайте уреда и принадлежностите му на тъмно, сухо и защитено от замръзване място, недостъпно за деца.

Изхвърляне

Указанията за изхвърляне са посочени чрез пиктограмите върху уреда и/или опаковката.

Повредени и/или предназначени за изхвърляне уреди трябва да се предават в определените за това пунктове за рециклиране.

Гаранция

Гаранционният срок е 12 месеца при професионална употреба и 24 месеца за потребители и започва да тече от датата на покупката на уреда.

Гаранцията покрива единствено дефекти, дължащи се на материални или производствени несъответствия. При предявяване на гаранционна претенция трябва да се приложи оригиналният документ за покупка с посочена дата на продажба.

От гаранцията се изключват неправилна употреба, напр. претоварване на уреда, прилагане на сила, повреди от външно въздействие или от чужди тела. Неспазване

на ръководството за употреба и нормалното износване също не се покриват от гаранцията..

Важна информация за клиента

Моля, имайте предвид, че връщането на продукта – както в рамките, така и извън гаранционния срок – по принцип трябва да бъде в оригиналната опаковка. Така ефективно се избягват ненужни транспортни повреди и често спорното им уреждане. Само в оригиналния кашон уредът ви е оптимално защитен и така се гарантира безпроблемна обработка.

Сервиз

Имате технически въпроси? Рекламация? Нуждаете се от резервни части или ръководство за експлоатация? В секция „Сервиз“ на уебсайта на Güde GmbH & Co. KG (www.guede.com) ще ви съдействаме бързо и без излишни формалности. Помогнете ни да ви помогнем: за да идентифицираме уреда ви при рекламация, са ни необходими серийният номер, артикулният номер и годината на производство. Всички тези данни ще откриете на табелката с данни.

Тел.: +49 (0) 79 04 / 700-360

Факс: +49 (0) 79 04 / 700-51999

Е-поща: support@ts.guede.com

Отстраняване на неизправности

Неизправност	Възможна причина	Препоръчително решение
Двигателят не стартира	<ol style="list-style-type: none"> 1. Празен резервоар 2. Замърсен въздушен филтър 3. Няма искра 4. Двигателят е „удавен“ 	<ol style="list-style-type: none"> 1. Напълнете догоре; проверете дали в карбуратора има гориво; проверете вентилацията на резервоара и отпушете отвора в капачката с игла 2. Почистете въздушния филтър 3. Почистете свещта, при нужда я сменете; проверете кабела на свещта; запалителната система да се провери в сервис 4. Развийте свещта, почистете и подсушете; при извадена свещ дръпнете стартовото въже няколко пъти
Двигателят прекъсва	<ol style="list-style-type: none"> 1. Кабелът на свещта е разхлабен 2. Горивопроводът е запушен или горивото е некачествено 3. Вентилацията в капачката на резервоара е запушена 4. В горивната система има вода или замърсявания 5. Въздушният филтър е замърсен 	<ol style="list-style-type: none"> 1. Натиснете плътно лулата върху свещта 2. Почистете горивопровода, използвайте прясно гориво 3. Сменете капачката на резервоара 4. Източете горивото и заредете чисто, прясно гориво 5. Почистете въздушния филтър
Двигателят често изгасва на празен ход	<ol style="list-style-type: none"> 1. Междината на запалването е твърде голяма, свещта е повредена 2. Карбуратора не е настроен правилно 3. Въздушният филтър е замърсен 	<ol style="list-style-type: none"> 1. Регулирайте или сменете свещта 2. Настройте карбуратора 3. Почистете въздушния филтър
Задвижването не работи както трябва	<ol style="list-style-type: none"> 1. Проверете опъна на жилото на лоста за задвижване 2. Задвижването не работи 	<ol style="list-style-type: none"> 1. При нужда регулирайте опъна на въжето. 2. Уредът да бъде проверен в сервис.
Необичайни вибрации	<ol style="list-style-type: none"> 1. Ножът е повреден или затъпен. 2. Крепежните болтове са разхлабени 	<ol style="list-style-type: none"> 1. Сменете ножовете. 2. Затегнете крепежните болтове
Незадоволителен резултат	Затъпени ножове	Сменете ножовете.

План за инспекция и поддръжка

 При неспазване на плана за поддръжка е възможно да се повреди двигателят!

Периодичност на редовната поддръжка		Преди всяко пускане в експлоатация	След 1	След 3	След 6	След 12	След 24
			месец	месец	месец	месец	месец
			5 работни часа	25 работни часа	50 работни часа	100 работни часа	250 работни часа
Моторно масло (10W-40)	Проверка	✓					
	Подмяна		✓		✓		
Въздушен филтър	Проверка	✓					
	Подмяна				✓		
Запалителна свещ	Проверка и почистване					✓	
	Подмяна						✓

Извършвайте съответната поддръжка през посочения месец или след изтичане на зададените работни часове — което настъпи първо.