



Eco Wheeler
EW 406-125
#95555





DEUTSCH

Bitte lesen Sie die Betriebsanleitung vor Inbetriebnahme sorgfältig durch.

ENGLISH

Please read the instructions carefully before starting the machine.



INBETRIEBNAHME | STARTING-UP THE MACHINE | MISE EN SERVICE | MESSA IN FUNZIONE |
INBEDRIJFSTELLING | UVEDENÍ DO PROVOZU | UVEDENIE DO PREVÁDZKY | ÜZEMBE HELYEZÉS |
UVEDBA V POGON | PUŠTANJE U RAD | ПУСКАНЕ В ДЕЙСТВИЕ | PUNEREA ÎN FUNCȚIUNE |
PUŠTANJE U RAD _____

6

Deutsch

Technische Daten / Gerätebeschreibung / Sicherheitshinweise / Bestimmungsgemäße Verwendung / Verhalten im Notfall / Symbole / Wartung / Entsorgung / Gewährleistung / Service _____ 26

English

Technical Data / Device description / Safety Warnings / Specified Conditions of Use / Emergency procedure / Symbols / Maintenance / Disposal / Guarantee / Service _____ 32



Lieferumfang

н Scope of deliver
обхват на доставката

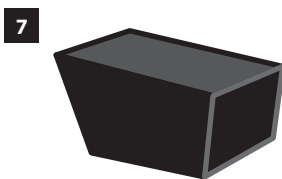
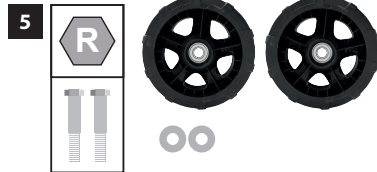
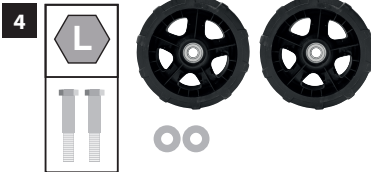

DE **Montage**

EN Assembly

BG Монтаж



5

8-10

DE **Inbetriebnahme**

EN Starting-up the machine

BG Пускане в действие



11-16

DE **Mähanweisungen**

EN Cutting instructions

BG Инструкции за сечене



17

DE **Betrieb**

EN Operation

BG Работа



18

DE **Reinigung / Wartung**

EN Cleaning / Maintenance

BG Чистене / Поддръжка RO

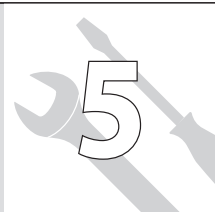

19-25

Gerätebeschreibung

N Device description

Описание на устройството



(1a) Резервоар за гориво

(2a) Горна част на кормилото

(1b) Стартер с ръчен механизъм

(2b) прекъсвач

(1c) Маслоизмервателна пръчка

(3) Долна част на кормилото

8

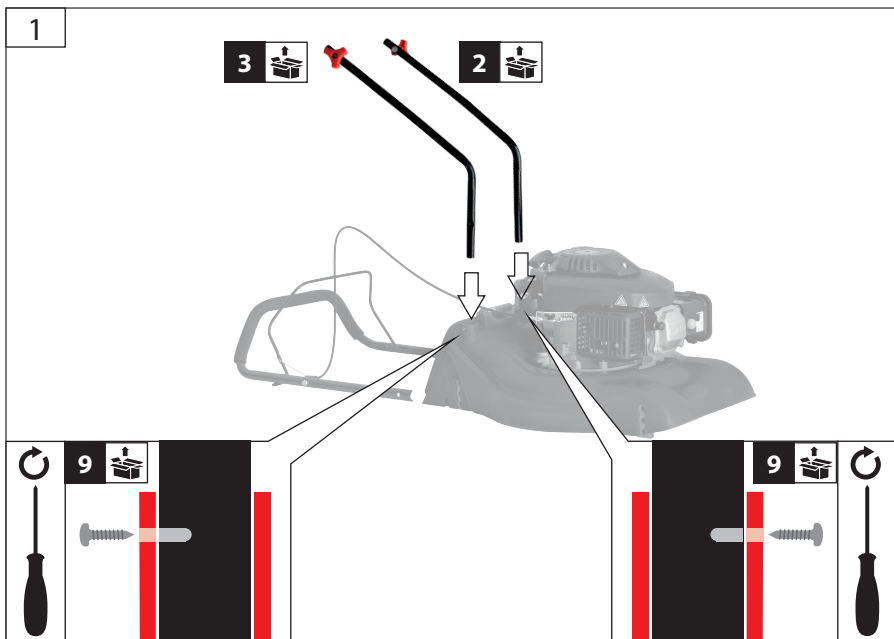
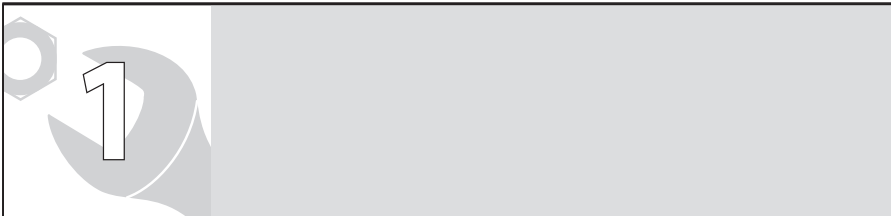

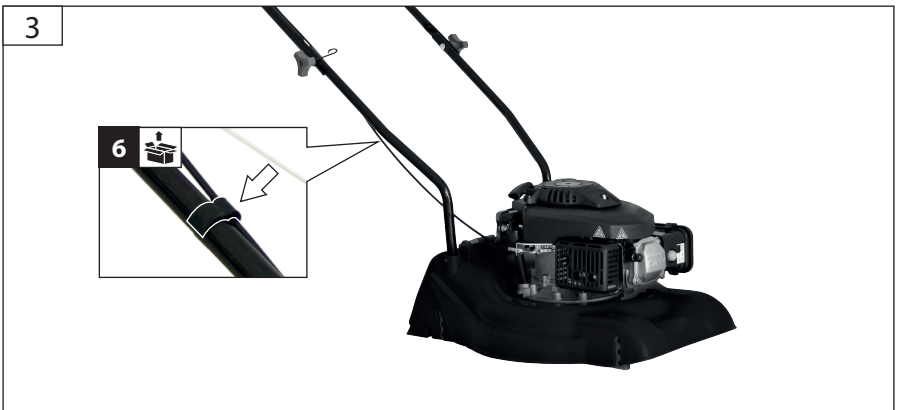
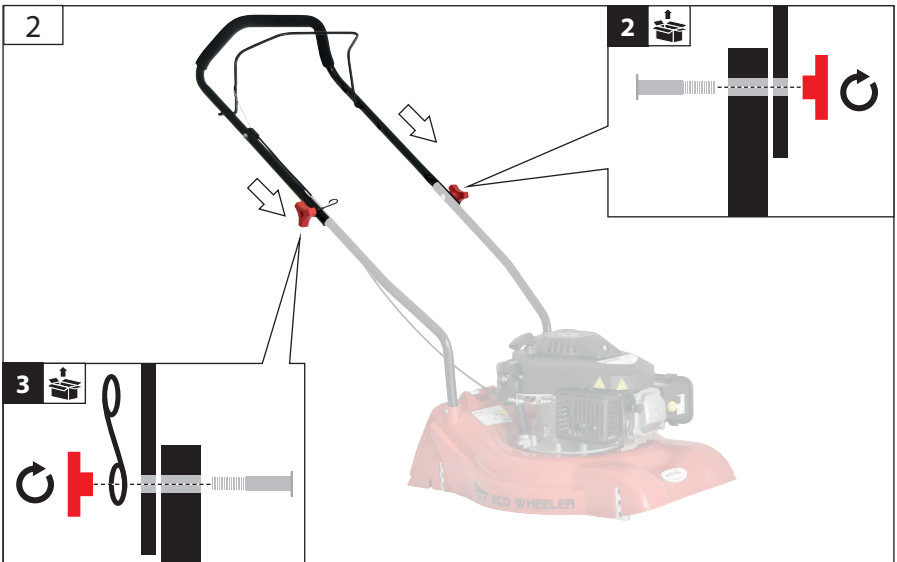

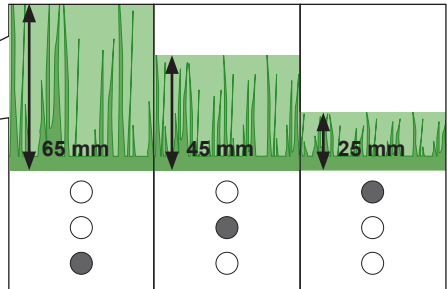
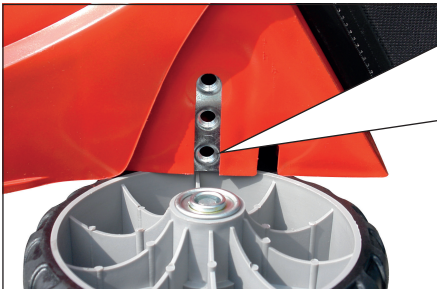
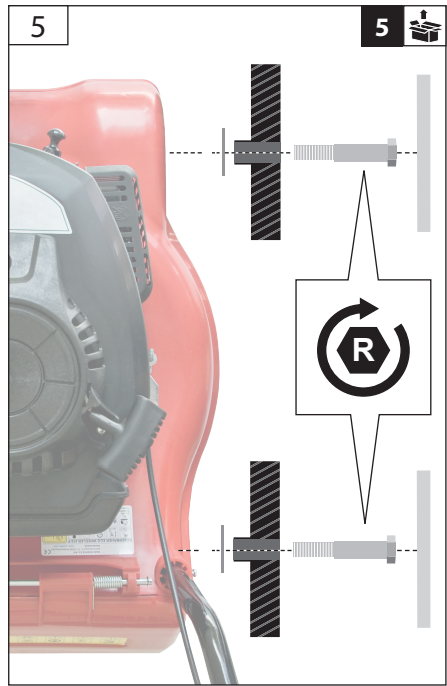
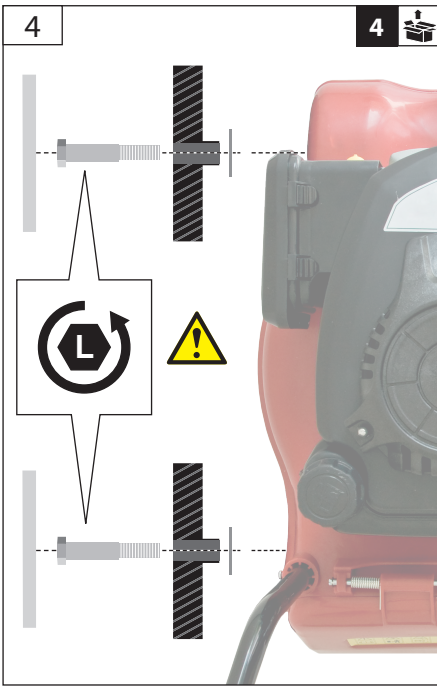

2



10W-40

DE Vor Erstinbetriebnahme muss der Motor unbedingt mit Motorenöl befüllt werden. Überprüfen Sie vor jeder Inbetriebnahme den Ölstand.

и Проверявайте нивото на маслото винаги, когато

уредът ще бъде пуснат в експлоатация. Долейте моторно масло, ако е необходимо. Проверявайте нивото на маслото всеки път, когато уредът ще бъде пуснат в експлоатация. Долейте моторно масло, ако е необходимо.

1

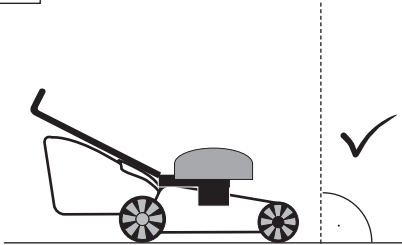

2

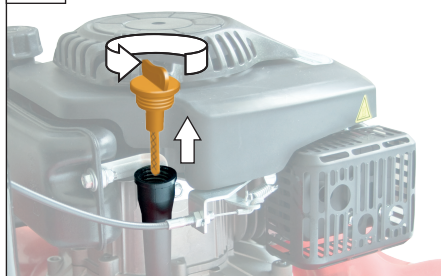

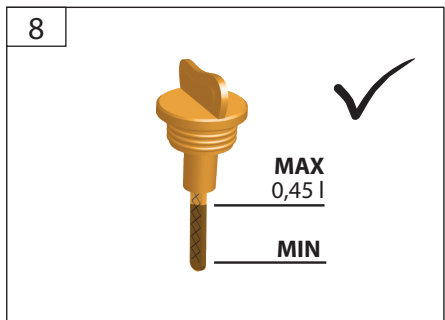
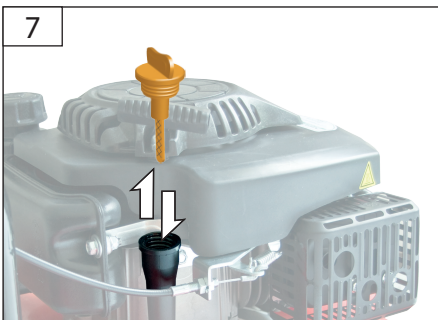
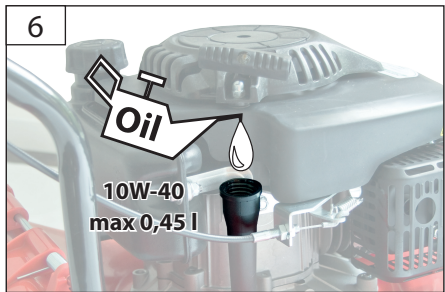
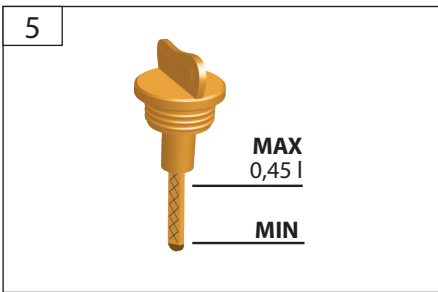
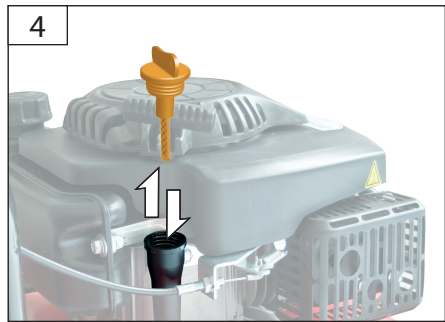
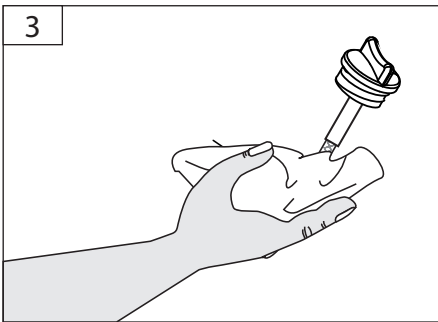



DE Aus Gründen der Qualitätssicherung wird jedes

Gerät einem Probelauf unterzogen und mit Motorenöl befüllt.

Vor dem Transport wird das Öl wieder abgelassen, es können sich jedoch Rückstände von Motorenöl am Messstab befinden. Bitte trotzdem Ölstand gewissenhaft überprüfen und Motorenöl nachfüllen.

За да се гарантира качество, всяко оборудване преминава през тестова експлоатация и се пълни с моторно масло. Маслото се източва преди транспортиране; въпреки това, може да има останало моторно масло по маслоизмервателната пръчка. Моля, проверете внимателно нивото на маслото и долейте отново моторно масло.



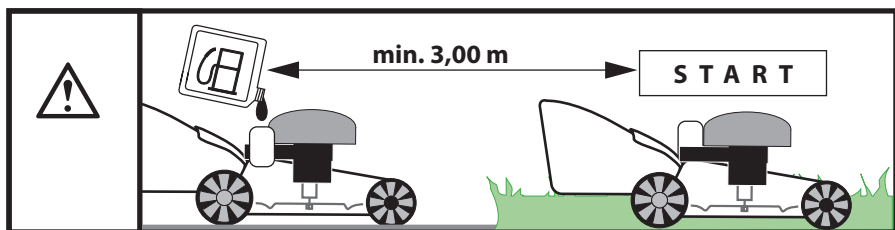
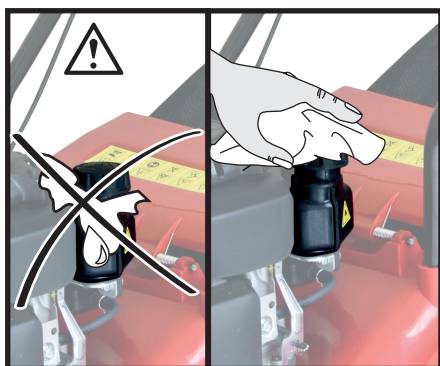
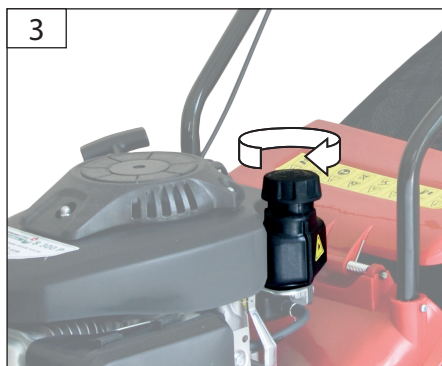
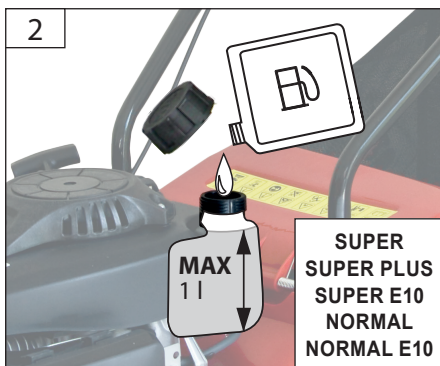
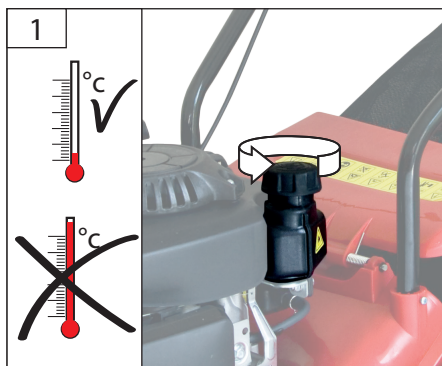

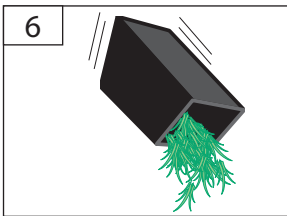
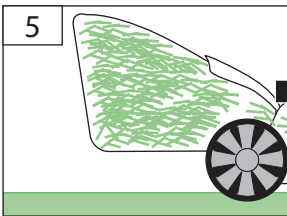
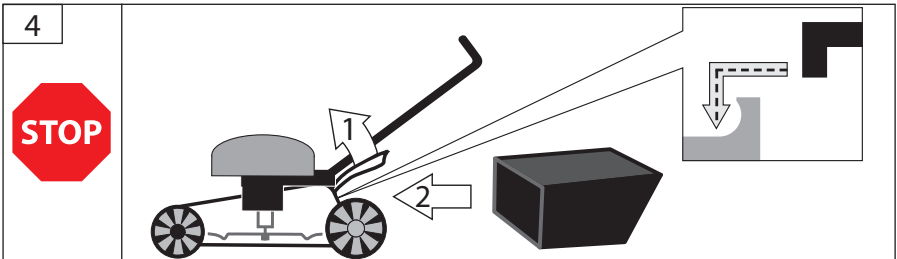
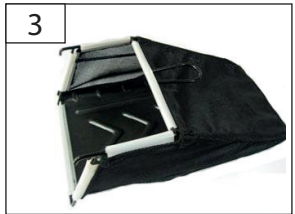
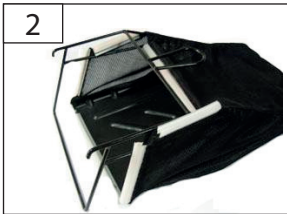
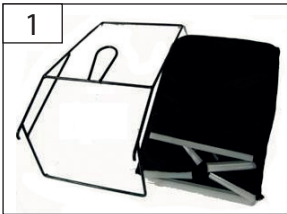
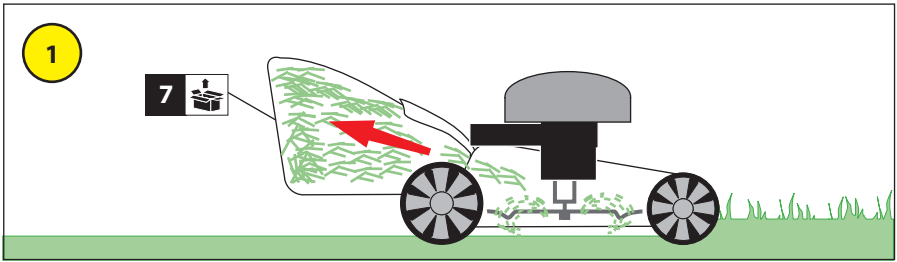

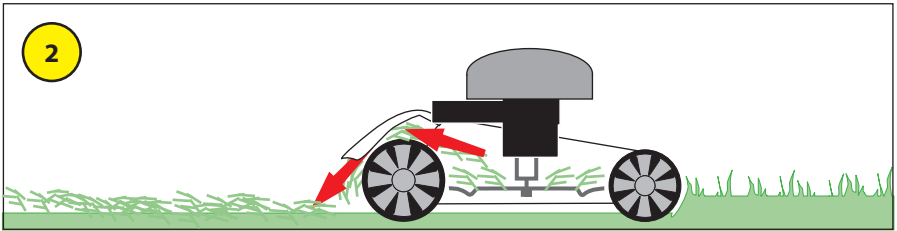
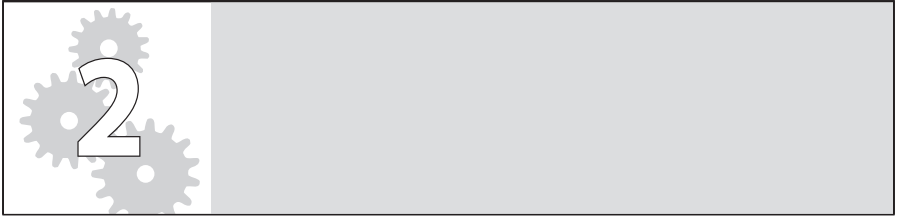

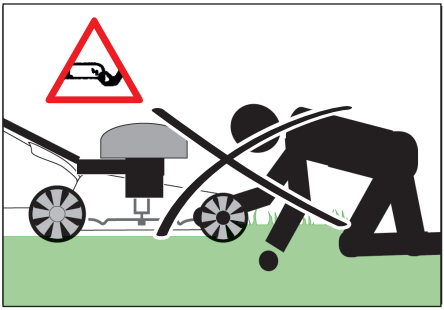
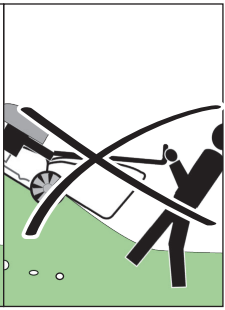
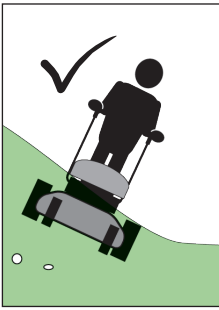
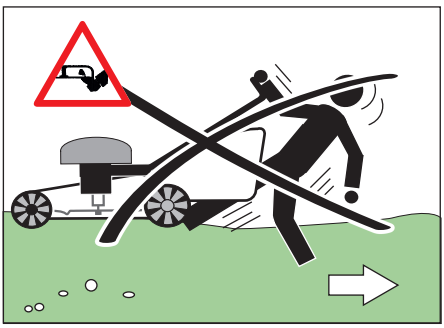
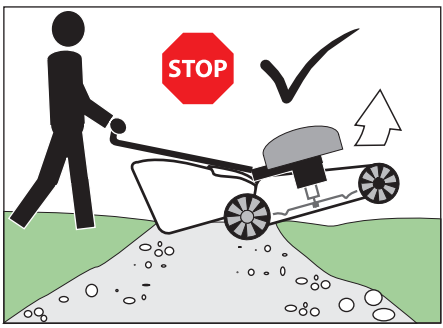
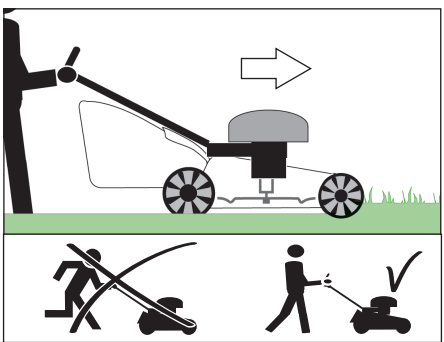
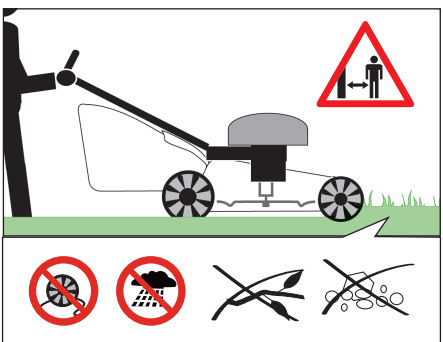

START 4 STOP

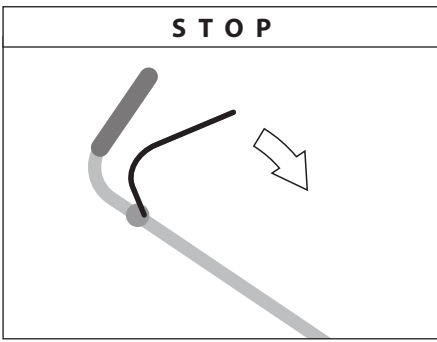
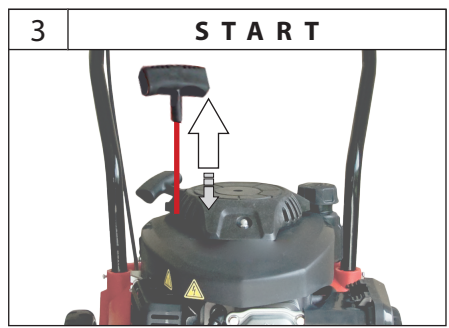
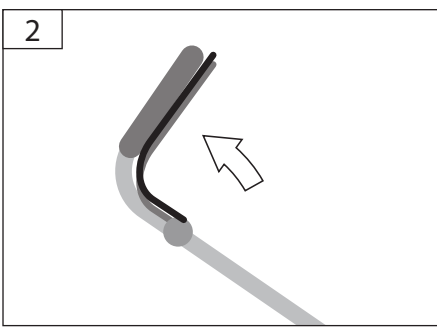
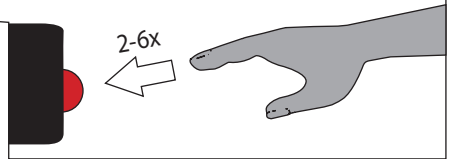
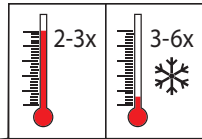
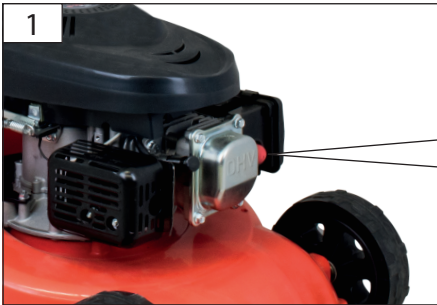

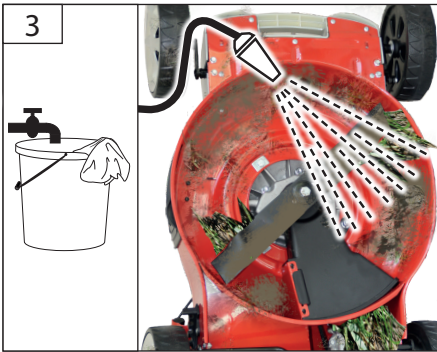
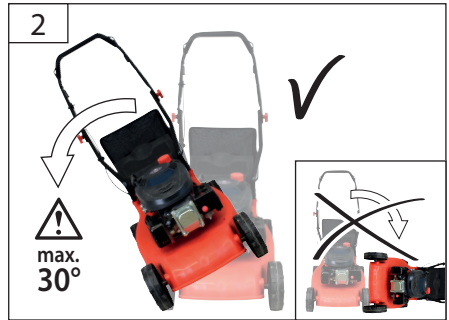
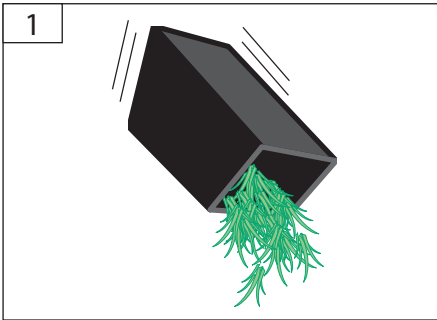

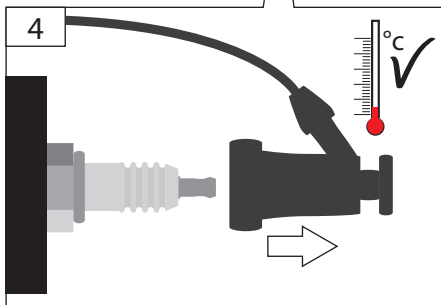
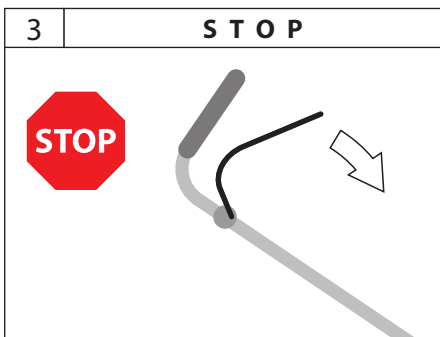
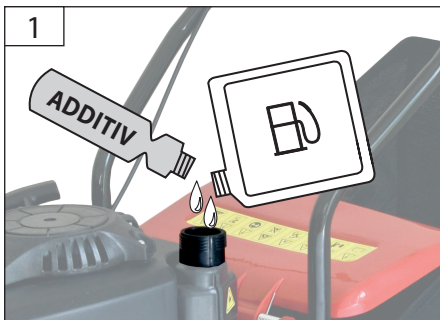
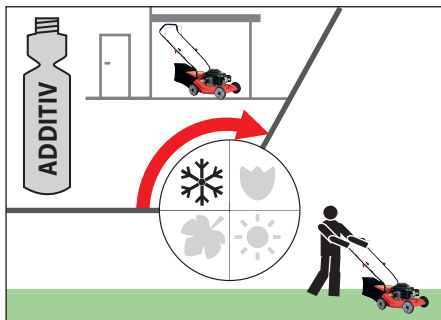

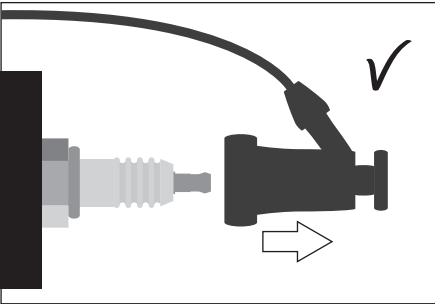
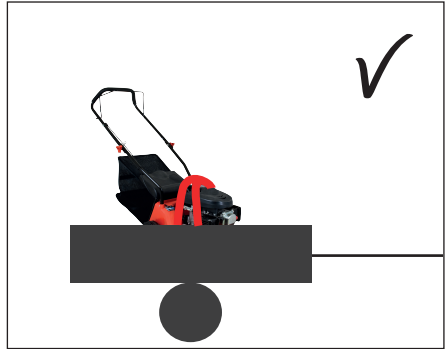

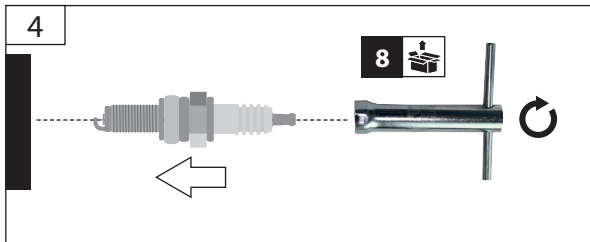
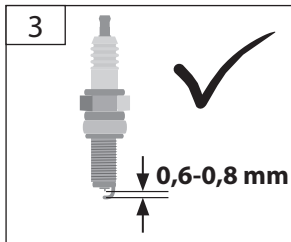
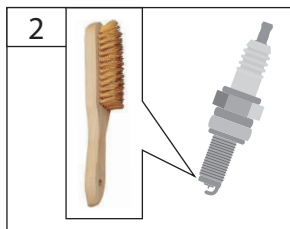
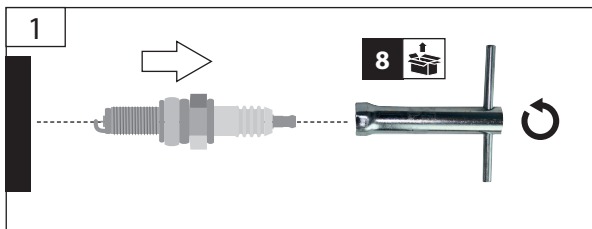
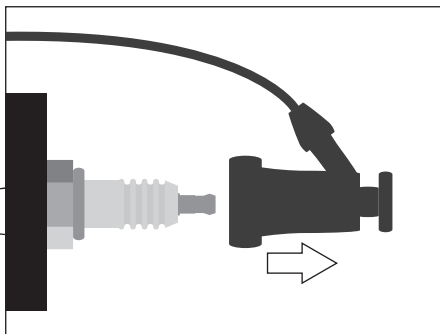
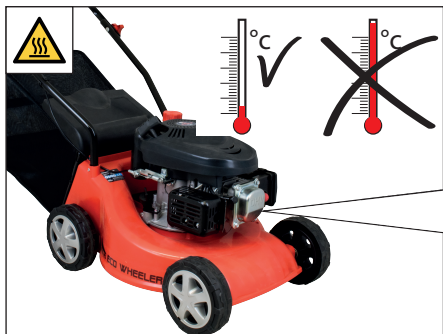

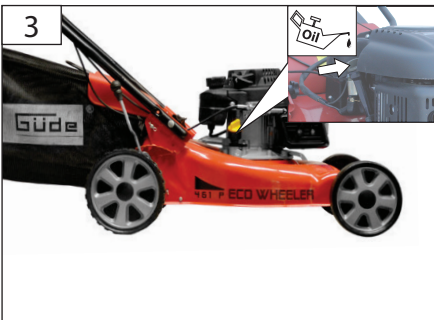
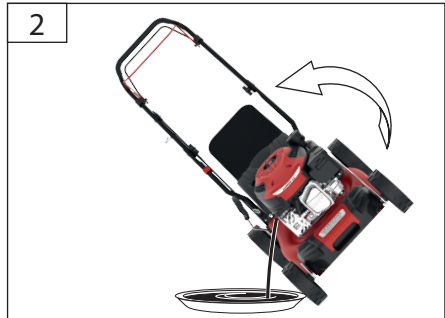
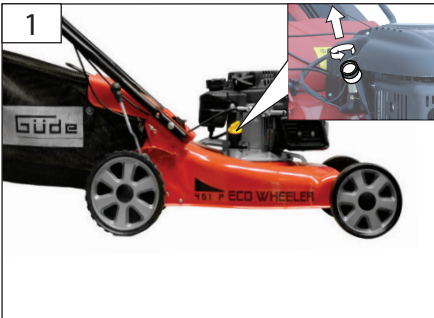

9

10

11

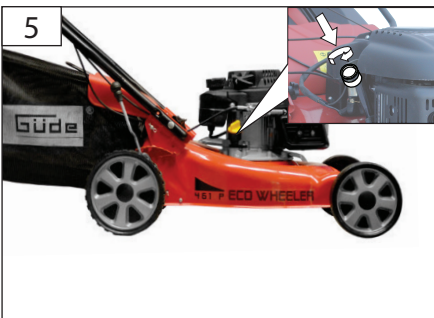

Tipp



#95367

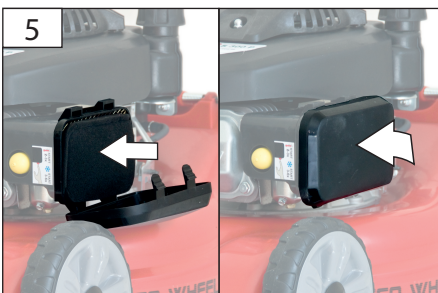
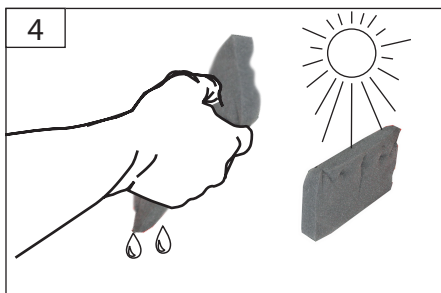
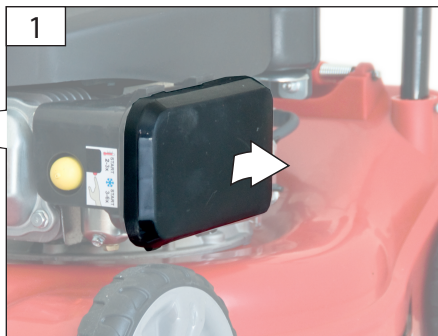

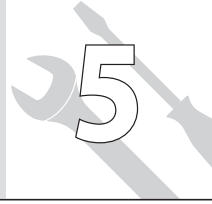

Моторът не стартира

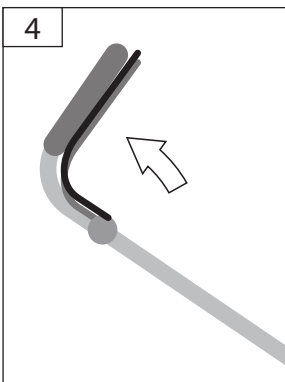
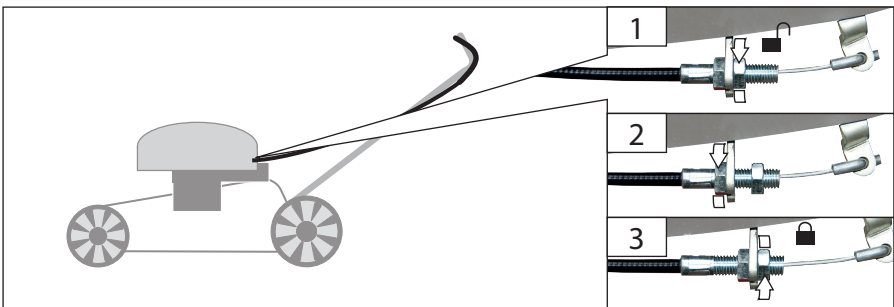

Technische Daten

Benzin-Rasenmäher		Eco Wheeler EW 406-125
Artikel-Nr.		95555
Motortyp		4-Takt-Motor
Motorleistung		2,1 kW (2,86 PS)
Hubraum		125 cm ³
Nenndrehzahl		3000 1/min
Schnittbreite		406 mm
Schnitthöhenverstellung		25 45 65 mm
Fangsackvolumen		45 l
Kraftstoff		Benzin
Startsystem		Reversierstart
Motoröl 0,45 l		10W40
Reifengröße hinten		152 mm
Reifengröße vorne		152 mm
Gewicht Netto/Brutto		17,5 / 22 kg

Geräuschangaben

Schalldruckpegel $L_{PA}^{1)}$	74,61 dB (A)
Gemessener Schalleistungspegel $L_{WA}^{2)}$	94,09 dB (A)
Garantierter Schalleistungspegel $L_{WA}^{3)}$	96 dB (A)

Gemessen nach ¹⁾ EN ISO 5395-1:2013; ^{2) 3)} 2000/14/EG;

¹⁾ Unsicherheit K = 3 dB (A);

²⁾ Unsicherheit K = 1,15 dB (A),
Gehörschutz tragen!

Vibrationsangaben

Schwingungsgesamtwerte (Vektorsumme dreier Richtungen) ermittelt entsprechend EN ISO 5395-1:2013

Schwingungsemissionswert a_h	max. 4,0 m/s ²
Unsicherheit K = 1,5 m/s ²	

WARNUNG: Der tatsächliche Schwingungsemissionswert kann sich je nach Art und Weise der Anwendung vom angegebenen Wert unterscheiden. Der Schwingungspegel kann für den Vergleich von Elektrowerkzeugen miteinander verwendet werden.

Er eignet sich auch für eine vorläufige Einschätzung der Schwingungsbelastung.

Für eine genaue Abschätzung der Schwingungsbelastung sollten auch die Zeiten berücksichtigt werden, in denen das Gerät abgeschaltet ist oder zwar läuft, aber nicht tatsächlich im Einsatz ist. Dies kann die Schwingungsbelastung über den gesamten Arbeitszeitraum deutlich reduzieren.

Legen Sie zusätzliche Sicherheitsmaßnahmen zum Schutz der Bedienperson vor der Wirkung von Schwingungen fest wie zum Beispiel: Wartung von Elektrowerkzeug und Einsatzwerkzeugen, Warmhalten der Hände, Organisation der Arbeitsabläufe.



Benutzen Sie das Gerät erst nachdem Sie die Bedienungsanleitung aufmerksam gelesen und verstanden haben. Machen Sie sich mit den Bedienungselementen und dem richtigen Gebrauch des Gerätes vertraut. Beachten Sie alle in der Anleitung aufgeführten Sicherheitshinweise. Verhalten Sie sich verantwortungsvoll gegenüber anderen Personen. Der Bediener ist verantwortlich für Unfälle oder Gefahren gegenüber Dritten. Falls über den Anschluss und die Bedienung des Gerätes Zweifel entstehen sollten, wenden Sie sich an den Kundendienst.

Bestimmungsgemäße Verwendung

Der Rasenmäher ist für das Schneiden von Rasen und Grasflächen mit einer maximalen Hang-Steigung von 20° im privaten Haus- und Hobbygarten bestimmt.

Dieses Gerät darf nur wie angegeben bestimmungsgemäß verwendet werden. Bei Nichtbeachtung der Bestimmungen, aus den allgemein gültigen Vorschriften sowie den Bestimmungen aus dieser Anleitung, kann der Hersteller für Schäden nicht verantwortlich gemacht werden.

⚠ Benutzen Sie das Gerät nur im Außenbereich und niemals in geschlossenen oder schlecht belüfteten Räumen.

⚠ Der Rasenmäher darf nicht eingesetzt werden zum Trimmen von Büschen, Hecken und Sträuchern, zum Schneiden und Zerkleinern von Rankgewächsen oder Rasen auf Dachpflanzungen oder in Balkonkästen. Weiterhin darf der Rasenmäher nicht als Häcksler zum Zerkleinern von Baum- und Heckenabschnitten sowie zum Einebnen von Bodenunebenheiten verwendet werden.

Anforderungen an den Bediener

Der Bediener muss vor Gebrauch des Gerätes aufmerksam die Bedienungsanleitung gelesen und verstanden haben.

Dieses Gerät ist nicht dafür bestimmt, durch Personen (einschließlich Kinder) mit eingeschränkten physischen, sensorischen oder geistigen Fähigkeiten oder mangels Erfahrung und/oder mangels Wissen benutzt zu werden, es sei denn, sie werden durch eine für ihre Sicherheit zuständige Person beaufsichtigt oder erhalten von ihr Anweisungen, wie das Gerät zu benutzen ist.

Qualifikation: Außer einer ausführlichen Einweisung durch eine sachkundige Person ist keine spezielle Qualifikation für den Gebrauch des Gerätes notwendig.

Mindestalter: Das Gerät darf nur von Personen betrieben werden, die das 16. Lebensjahr vollendet haben. Eine Ausnahme stellt die Benutzung als Jugendlicher dar, wenn die Benutzung im Zuge einer Berufsausbildung zur Erreichung der Fertigkeit unter Aufsicht eines Ausbilders erfolgt.

Örtliche Bestimmungen können das Mindestalter des Benutzers festlegen.

Schulung: Die Benutzung des Gerätes bedarf lediglich einer entsprechenden Unterweisung durch eine Sachkundige Person bzw. die Bedienungsanleitung. Eine spezielle Schulung ist nicht notwendig.

Verhalten im Notfall

⚠ Verletzungsgefahr!

Bringen Sie Hände oder Füße nie in die Nähe von rotierenden Teilen. Halten Sie immer Abstand zur Auswurföffnung.

⚠ Verbrennungsgefahr!

Einige Maschinenteile werden beim Betrieb sehr heiß. Heiße Teile, z.B. Motor und Schalldämpfer nicht berühren.

Leiten Sie die der Verletzung entsprechend notwendige Erste Hilfe Maßnahmen ein und fordern Sie schnellst möglich qualifizierte ärztliche Hilfe an. Bewahren Sie den Verletzten vor weiteren Schädigungen und stellen Sie diesen ruhig. Für einen eventuell eintretenden Unfall sollte immer ein Verbandskasten nach DIN 13164 am Arbeitsplatz griffbereit vorhanden sein. Dem Verbandskasten entnommenes Material ist sofort wieder aufzufüllen. Wenn Sie Hilfe anfordern, machen Sie folgende Angaben

1. Ort des Unfalls
2. Art des Unfalls
3. Zahl der Verletzten
4. Art der Verletzungen

Symbole

	Achtung!
	Zur Verringerung eines Verletzungsrisikos Betriebsanleitung lesen
	Gehörschutz tragen. Schutzbrille tragen.
	Sicherheitsschuhe mit Schnitenschutz, griffiger Sohle und Stahlkappe tragen!
	Schnell
	Langsam
	Vor allen Arbeiten am Gerät Motor abstellen und Zündkerzenstecker ziehen.
	Warnung vor wegschleudernden Teilen
	① Den Ölstand überprüfen, gegebenenfalls nachfüllen.
	② Benzin tanken.
	Primer 3x betätigen, wenn der Motor warm ist. Primer 6x betätigen, wenn der Motor kalt ist.
	Sammeln
	Mähen
	Warnung vor heißen Oberflächen!
	Warnung vor gefährlicher elektrischer Spannung!
	Warnung vor scharfen Messern. Die Messer laufen auch nach dem Ausschalten noch kurz nach.
	Halten Sie in der Nähe stehende Personen auf sicheren Abstand zur Maschine (mindestens 5 m).
	Vor allen Arbeiten am Gerät Motor ausschalten.

	Rauchen und offenes Feuer verboten.
	Halten Sie Kinder von der Maschine fern.
	Lagern Sie das Gerät trocken und frostgeschützt.
	Garantierter Schalleistungspegel L _{WA}
	Vor Nässe schützen.
	Packungsorientierung oben

Sicherheitshinweise

⚠ Warnung

Lesen Sie alle Sicherheitshinweise und Anweisungen. Versäumnisse bei der Einhaltung der Sicherheitshinweise und Anweisungen können elektrischen Schlag, Brand und/oder schwere Verletzungen verursachen. **Bewahren Sie alle Sicherheitshinweise und Anweisungen für die Zukunft auf.**

Halten Sie Kinder und andere Personen sowie Tiere während der Benutzung des Geräts fern. Der Mindest-Sicherheitsabstand beträgt 5 m.

Tragen Sie persönliche Schutzausrüstung.

Tragen Sie geeignete Arbeitskleidung wie festes Schuhwerk mit rutschfester Sohle, eine robuste, lange Hose, Handschuhe, eine Schutzbrille und Gehörschutz!

Tragen Sie Schutzhandschuhe, wenn dies notwendig ist. Benutzen Sie das Gerät nur bei Tageslicht oder in gut beleuchteter Umgebung.

Das Gerät muss vor dem Gebrauch sorgfältig überprüft werden. Arbeiten Sie ausschließlich mit Geräten, die in einwandfreiem Zustand sind. Sollten Sie einen Defekt an dem Gerät bemerken, der möglicherweise eine Gefahr für den Bediener darstellen kann, betreiben Sie das Gerät erst nachdem der Defekt beseitigt wurde.

Überprüfen Sie sorgfältig das Gelände, auf dem die Maschine eingesetzt wird, und entfernen Sie alle Gegenstände, die erfasst und weggeschleudert werden können.

Seien Sie aufmerksam, achten Sie darauf, was Sie tun, und gehen Sie mit Vernunft an die Arbeit mit einem Elektrowerkzeug. Benutzen Sie kein Elektrowerkzeug, wenn Sie müde sind oder unter dem Einfluss von Drogen, Alkohol oder Medikamenten stehen.

Niemals bei laufendem Gerät unter das Gehäuse fassen. Halten Sie immer Abstand zur Auswurföffnung.

Vermeiden Sie ein versehentliches Starten. Befinden Sie sich immer in der Startstellung, wenn Sie das Starterseil ziehen.

⚠ Kraftstoff ist leicht entflammbar.

Bewahren Sie Kraftstoff nur in dafür zugelassenen Behältern auf.

Maschine nur im Freien und nicht in der Nähe von offenen Flammen bzw. brennenden Zigaretten tanken.

Tanken Sie vor dem Starten der Maschine. Während der Motor läuft oder noch heiß ist, darf nicht nachgetankt werden oder der Tankdeckel geöffnet werden.

Achten Sie darauf, dass kein Kraftstoff verschüttet wird. Falls Kraftstoff übergelaufen ist, darf der Motor nicht gestartet werden. Entfernen Sie das Gerät von der verschmutzten Stelle und vermeiden Sie jeglichen Zündversuch, bis sich die Kraftstoffdämpfe verflüchtigt haben.

Vor Erstinbetriebnahme muss der Motor unbedingt mit Motorenöl befüllt werden.

Überprüfen Sie vor jeder Inbetriebnahme den Ölstand. Füllen Sie ggf. Motorenöl nach.

⚠ Vergiftungsgefahr!

Abgase, Kraftstoffe und Schmierstoffe sind giftig. Das Einatmen von Abgasen kann tödlich sein!

Benutzen Sie das Gerät nur im Außenbereich und niemals in geschlossenen oder schlecht belüfteten Räumen.

Maschine nicht in einem geschlossenen Bereich betreiben, in dem sich gefährliche Kohlenmonoxydgase sammeln können.

Führen Sie vor Benutzung stets eine Sichtprüfung durch, um festzustellen, ob das Gerät, insbesondere Schneidwerkzeuge, Befestigungsteile oder die gesamte Schneideinheit, beschädigt ist.

Der Rasenmäher darf nicht betätigt werden, ohne dass entweder die vollständige Grasfangeinrichtung oder die selbstschließende trennende Schutzeinrichtung für die Auswurföffnung angebracht ist

⚠ Überprüfen Sie vor jeder Inbetriebnahme sämtliche Schraub- und Steckverbindungen sowie Schutzeinrichtungen auf Festigkeit und richtigen Sitz und ob alle beweglichen Teile leichtgängig sind.

⚠ Überprüfen Sie vor jeder Inbetriebnahme alle Startarretierungen und Tastschalter auf ordnungsgemäße Funktion.

⚠ Es ist strengstens untersagt, die an der Maschine befindlichen Schutzeinrichtungen zu demontieren, abzuändern oder Zweck zu entfremden oder fremde Schutzeinrichtungen anzubringen.

⚠ Es ist strengstens untersagt jegliche versiegelten Einrichtungen zur Motordrehzahl zu verändern/manipulieren.

⚠ Das Gerät darf nicht benutzt werden falls es beschädigt ist oder die Sicherheitseinrichtungen defekt sind. Tauschen Sie abgenutzte und beschädigte Teile aus.

Starten Sie den Motor erst dann, wenn Ihre Füße in sicherem Abstand von den Schneidwerkzeugen sind. Kippen Sie die Maschine nicht beim Starten.

Starten Sie die Maschine nicht, wenn Sie vor der Auswurföffnung stehen.

Achten Sie auf sicheren Stand, besonders an Hängen. Arbeiten Sie nicht an übermäßig steilen Hängen. Seien Sie besonders vorsichtig, wenn Sie an Hängen die Fahrtrichtung wechseln.

Es ist gefährlich an Hängen, Gräben, Deichen, in der Nähe von Müllhalden oder ähnlichem zu mähen.

Vermeiden Sie eine abnormale Körperhaltung. Sorgen Sie für einen sicheren Stand und halten Sie jederzeit das Gleichgewicht. Achtung beim Rückwärtsgehen, Stolpergefahr!

Sorgen Sie bei der Arbeit mit dem Gerät immer für ausreichende Beleuchtung bzw. gute Lichtverhältnisse. Mangelhafte Beleuchtung/ Lichtverhältnisse stellen ein hohes Sicherheitsrisiko dar.

Die Verwendung der Maschine unter Schlechtwetterbedingungen, insbesondere bei Blitzrisiko, ist zu vermeiden.

Vermeiden Sie den Gebrauch des Geräts auf nassem Gras, soweit möglich.

Gehen Sie! Nicht rennen!

Seien Sie äußerst vorsichtig, wenn Sie wenden und die Maschine zu sich heranziehen.

Schalten Sie den Rasenmäher immer ab, wenn er getragen, gekippt oder außerhalb von Rasenflächen bewegt wird. Warten Sie, bis alle rotierenden Teile zum Stillstand gekommen sind.

Falls ein Fremdkörper getroffen wird oder Vibrationen auftreten, müssen Sie das Gerät abstellen und den Zündkerzenstecker abziehen. Kontrollieren Sie, ob das Gerät beschädigt ist. Eventuelle Schäden reparieren.

Schalten Sie die Maschine sofort ab, nachdem Sie Ihre Arbeit beendet haben.

Fangsack nie bei laufendem Gerät abnehmen. Schalten Sie die Maschine immer vor dem Anbringen oder Entfernen des Fangsacks ab.

Maschine nicht unmittelbar nach dem Abschalten in geschlossenen Räumen abstellen, sondern im Freien

abkühlen lassen.

Bewahren Sie niemals die Maschine mit Benzin im Tank innerhalb eines Gebäudes auf, in dem möglicherweise Benzindämpfe mit offenem Feuer oder Funken in Berührung kommen können.

Bei längerer Lagerung Maschine nur mit leerem Tank aufbewahren.

Ersetzen Sie defekte Schalldämpfer.

Ändern Sie nicht die Regeleinstellung des Motors und überdrehen Sie ihn nicht.

Wartung



Vor allen Arbeiten am Gerät Motor abstellen und Zündkerzenstecker ziehen. Warten Sie, bis alle rotierenden Teile zum Stillstand gekommen sind und sich das Gerät abgekühlt hat.

Maschine, insbesondere Tank- und Motorbereich, stets sauber halten. Grasauswurf und Gehäuse regelmäßig reinigen.

Entfernen Sie regelmässig alle Rasen- und Unkrautreste um ein Überhitzen des Schaftrohrs zu vermeiden. Rasen-/Gras-/Unkrautreste verfangen sich unterhalb des Schutzschildes, dies verhindert eine ausreichende Kühlung des Schaftrohrs. Entfernen Sie die Reste vorsichtig mit einem Schraubenzieher oder dergleichen.

Um die Brandgefahr auf ein Minimum einzuschränken, die Zylinderrippen häufig mit Pressluft reinigen und den Bereich des Schalldämpfers von Zweigresten, Blättern oder anderen Rückständen befreien.

Um die Brandgefahr möglichst gering zu halten, müssen Motor und Auspuff frei von Gras, Laub und überschüssigem Schmierfett sein.

Behandeln Sie alle beweglichen Teile mit einem umweltfreundlichen Öl.

Überprüfen Sie den Auffangsack regelmäßig auf Abnutzung und Alterung.

Reparaturen und Arbeiten, die nicht in dieser Anleitung beschrieben wurden, nur von qualifiziertem Fachpersonal durchführen lassen.

Nur Originalzubehör und Originalersatzteile verwenden. Bauteile, deren Austausch nicht beschrieben wurde, nur beim Hersteller auswechseln lassen.

Das Verwenden nicht originaler Ersatzteile ist nicht gestattet. Bei Verwendung nicht originaler Ersatzteile können wir nicht für eine ordnungsgemäße Funktion garantieren.

Nur ein regelmäßig gewartetes und gut gepflegtes Gerät kann ein zufriedenstellendes Hilfsmittel sein. Wartungs- und Pflegemängel können zu unvorhersehbaren Unfällen und Verletzungen führen.

Gewährleistung

Die Gewährleistung erstreckt sich ausschließlich auf Mängel, die auf Material- oder Herstellungsfehler zurückzuführen sind. Bei Geltendmachung eines Mangels im Sinne der Gewährleistung ist der original Kaufbeleg mit Verkaufsdatum beizufügen.

Von der Gewährleistung ausgeschlossen sind unsachgemäße Anwendungen, wie z. B. Überlastung des Gerätes, Gewaltanwendung, Beschädigungen durch Fremdeinwirkung oder durch Fremdkörper. Nichtbeachtung der Betriebsanleitung und normaler Verschleiß sind ebenfalls von der Gewährleistung ausgeschlossen.

Service

Sie haben technische Fragen? Eine Reklamation?

Benötigen Ersatzteile oder eine Betriebsanleitung? Auf der Homepage der Firma Güde GmbH & Co. KG (www.guede.com) im Bereich Service helfen wir Ihnen schnell und unbürokratisch weiter. Bitte helfen Sie uns Ihnen zu helfen. Um Ihr Gerät im Reklamationsfall identifizieren zu können benötigen wir die Seriennummer sowie Artikelnummer und Baujahr. Alle diese Daten finden Sie auf dem Typenschild. Um diese Daten stets zur Hand zu haben, tragen Sie diese bitte unten ein.

Seriennummer:

Artikelnummer:

Baujahr:

Inspektions- und Wartungsplan

⚠ Bei Nichteinhaltung des Wartungsplanes kann es zu Schäden am Motor kommen!

Regelmäßige Wartungsperiode		Vor jeder Inbetriebnahme	Nach 1 Monat	Nach 3 Monaten	Nach 6 Monaten	Nach 12 Monaten	Nach 24 Monaten
			5 Betriebsstunden	25 Betriebsstunden	50 Betriebsstunden	100 Betriebsstunden	250 Betriebsstunden
Motoröl (10W-40)	Kontrollieren	✓					
	Ersetzen		✓		✓		
Luftfilter	Kontrollieren	✓					
	Ersetzen				✓		
Zündkerze	Kontrollieren					✓	
	Reinigen						
	Ersetzen						✓

Die entsprechende Wartung im angegebenen Monat oder nach dem Ablauf der vorgegebenen Betriebsstunden durchführen - je nach dem, was früher eintritt.

Störungssuche

Störung	Ursache	Behebung
Der Motor startet nicht	Start-Stop-Hebel nicht betätigt	Start-Stop-Hebel betätigen
	Primer Pumpe nicht betätigt	Primer Pumpe betätigen
	Kraftstoffmangel	Kraftstoff nachfüllen
	Bowdenzüge zu lange	Bowdenzüge durch Überwurfmutter nachstellen.
	schlechter Kraftstoff, Lagerung ohne Entleerung des Benzintanks, falsche Benzinsorte	Kraftstofftank und Vergaser entleeren. Frisches Benzin einfüllen.
	Zündkerze verschmutzt, (Kohlerückstände auf den Elektroden), Elektrodenabstand zu groß	Kerze reinigen, Wärmewert der Kerze kontrollieren evtl. Zündkerze erneuern, 0,6-0,8 mm einstellen
	Die Zündkerze ist nass vom Benzin (abgeöffneter Motor).	Zündkerze trocknen und erneut einsetzen.
Gras wird nicht gesammelt	Kanal verstopft	Auswurfkanal reinigen
	Grasfangsack voll Gras zu nass	Grasfangsack leeren bei trockenem Wetter mähen

Technical Data

Petrol Lawnmower

Eco Wheeler EW 406-125

Art. No	95555
Engine Type	4-stroke motor
Motor power	2,1 kW (2,86 PS)
Contents	125 cm ³
Rated speed	3000 1/min
Cutting width	406 mm
Cutting height adjustment	25 45 65 mm
Collection bag capacity	45 l
Fuel	Benzin
Starting system	Recoil starter
Engine oil 0,45 l	10W40
wheel size behind	152 mm
wheel size ahead	152 mm
Net/gross weight	17,5 / 22 kg

Noise details

Sound pressure level L_{pA} ¹⁾	74,61 dB (A)
Measured sound power level L_{WA} ²⁾	94,09 dB (A)
Guaranteed sound power level L_{WA} ³⁾	96 dB (A)

Measured according to ¹⁾EN ISO 5395-1:2013; ²⁾³⁾ 2000/14/EG;

¹⁾Uncertainty K = 3 dB (A);

²⁾Uncertainty K = 1,15 dB (A),

Wear ear protectors!

Vibration details

Vibration total values (triaxial vector sum) determined according to EN ISO 5395-1:2013

Vibration emission value a_h max. 4,0 m/s²

Uncertainty K = 1,5 m/s²

WARNING: The vibration emission level will vary because of the ways in which a power tool can be used and may increase above the level given in this information sheet. The vibration emission level may be used to compare one tool with another.

It may be used for a preliminary assessment of exposure.

An estimation of the level of exposure to vibration should also take into account the times when the tool is switched off or when it is running but not actually doing the job. This may significantly reduce the exposure level over the total working period.

Identify additional safety measures to protect the operator from the effects of vibration such as: maintain the tool and the accessories, keep the hands warm, organisation of work patterns.

Read and understand the operating instructions before using the appliance. Familiarise with the control

elements and how to use the appliance properly. Abide by all the safety measures stated in the service manual. Act responsibly toward third parties. The operator is responsible for accidents or risks to third parties. In case of any doubts about connection and operation refer please to our customer center

Specified Conditions of Use

The mower is intended for the cutting of lawns and grassy areas with a maximum terrain inclination of 20° in private household and hobby gardens.

Do not use this product in any other way as stated for normal use. Not observing general regulations in force and instructions from this manual does not make the manufacturer liable for damages.

 Use the appliance only outside, never use it in confined and bad ventilated areas.

 The mower must not be used for cutting bushes, hedges and thickets, for cutting and mulching creepers or lawns on roofs or in balcony boxes. The mower must also not be used as a crusher for mulching tree cuttings and hedges or levelling any terrain roughness.

Requirements for operating staff

The operating staff must carefully read the Operating Instructions before using the appliance.

This appliance is not intended for use by persons (including children) with limited physical, sensory or mental capabilities or insufficient experience and/or knowledge unless they are supervised by a person who is responsible for their safety or have been instructed by them in the safe use of the appliance.

Qualification: Apart from the detailed instructions by a professional, no special qualification is necessary for appliance using.

Minimum age: Persons over 16 years of age can only work on the appliance. An exception includes youngsters trained in order to reach knowledge under supervision of the trainer during occupational education.

Local regulations may stipulate the minimum age of the user.

Training: Using the appliance only requires corresponding training by a professional or the Operating Instructions. No special training is necessary.

Emergency procedure

Risk of injury

Never put your hands and feet near the rotating parts. Keep a distance from the ejection opening at all times.

Danger of burns!

Some parts of the appliance get too hot when the appliance is operated. Do not touch any hot parts, e.g. engine and muffler.

Conduct a first-aid procedure adequate to the injury and summon qualified medical attendance as quickly as possible. Protect the injured person from further harm and calm them down. For the sake of eventual accident, in accordance with DIN 13164, a workplace has to be fitted with a first-aid kit. It is essential to replace any used material in the first-aid kit immediately after it has been used. If you seek help, state the following pieces of information

1. Accident site
2. Accident type
3. Number of injured persons
4. Injury type(s)

Symbols



Caution!



To reduce the risk of injury, user must read instruction manual



Wear ear protectors.
Wear goggles.



Wear safety cut through resistant shoes with safety sole and steel toe!



Quickly



Slow



Switch the engine off and remove the socket plug before any work on the engine.















Warning against thrown-off items



① Check the oil level, fill it up if required.



② Fill up with petrol.

	Activate the primer 3x if the motor is warm. Activate the primer 6x if the motor is cold.
	Collecting
	Mowing
	Warning against hot surfaces!
	Warning against dangerous voltage!
	Warning against sharp knives. Knives keep running for a short time after the appliance is switched off.
	Ensure others are a safe distance away from the machine (min. 5 m).
	Switch off the engine before any work on it.
	Prohibited smoking and open fire using.
	
	Keep the machine out of reach of children.
	The appliance must be stored in a dry place and protected from frost.
	Guaranteed sound power level L_{WA}
	Keep dry at all times.
	This side up

Safety Warnings

Read all safety warnings and all instructions. Failure to follow the warnings and instructions may result in electric shock, fire and/or serious injury. **Save all warnings and instructions for future reference.**

Keep children and other persons including animals in a safe distance when using the appliance. Minimum safe distance is 5 m.

Wear personal protective equipment.

Wear suitable protective clothing such as sturdy shoes with non-slip sole, robust long trousers, gloves, safety glasses and hearing protection!

Wear protective gloves if necessary.

Use the appliance in broad daylight or in a well-lit environment.

The appliance must be carefully inspected before use. Only work with appliances that are in a good condition. If you notice any defects on the appliance that may possibly represent a danger for the operator, then you may only use the appliance after the defect has been rectified.

Check carefully the terrain where the appliance is being used and remove any items that could get caught and be thrown away.

Stay alert, watch what you are doing and use common sense when operating a power tool. Do not use a power tool while you are tired or under the influence of drugs, alcohol or medication.

Never touch under the housing body when the engine is running. Keep a distance from the ejection opening at all times.

Avoid any inadvertent starting of the engine. Make sure that the control lever is always in 'Start' position when you pull the starter rope.

Fuel is highly flammable.

Keep the fuel in suitable containers only.

The appliance may only be refuelled outdoors and not near open fire or burning cigarettes.

Emergency procedure

Make sure the fuel does not overflow. If the fuel overflows, the engine must not be started. Remove any dirt from the appliance and prevent any attempt at ignition until fuel fumes have evaporated.

The engine must be filled with engine oil before the initial commissioning.

Check the oil level every time before commissioning. Fill with engine oil if required.

Risk of poisoning!

Exhaust fumes, fuel and lubricants are toxic substances. Breathing in exhaust fumes may be fatal! Use the appliance only outside, never use it in confined and bad ventilated areas.

Do not operate the unit in closed spaces where dangerous carbon monoxide gases may accumulate.

Always carry out a visual inspection before use, to check whether the appliance is damaged, in particular the cutting tools, the fastening components or the entire cutting unit.

The mower must not be operated without either the complete grass capture device or the self-closing removable protection device for the ejection opening being attached.

Check all screw and plug-in connections and protective equipment if firm and tightened properly and whether all moving parts are running smooth whenever the appliance is to be put into operation.

Check all start locking mechanisms and pushbuttons for their correct functioning every time before starting up.

The protective equipment on the appliance is strictly prohibited to be disassembled, changed, used in conflict with the designation and it is prohibited to attach any protective equipment of other manufacturers.

It is strictly prohibited to alter or manipulate any of the sealed devices for motor speed.

The appliance must not be used if damaged or safety equipment is defective. Replace any worn-out and damaged parts.

Do not start the engine before your feet are in a safe distance from the cutting tools.

Do not incline the appliance when being started.

Do not start the appliance when you are standing in front of the ejection opening.

Provide a safe posture, especially on slopes. Do not work on too steep slopes. Be particularly careful when changing travelling direction on slopes.

It is dangerous to mow on slopes, ditches, dykes or in the vicinity of rubbish dumps or similar places.

Do not overreach. Keep proper footing and balance at all times. Be careful when going backwards – risk of tripping!

Provide adequate lighting or good lighting conditions when working with the machine. Poor lighting/light conditions represent a high safety risk.

Do not use the appliance in bad weather, especially when there is a risk of storm.

Avoid operating the equipment in wet grass, where feasible.

Walk! Never run!

Pay maximum attention when turning around and pulling the appliance to you.

Switch the mower off whenever carrying or inclining it or when being outside a grass area. Wait until all rotating parts have stopped.

If an undesirable item is encountered or the appliance starts vibrating, the appliance must be switched off and the socket plug removed. Check whether the appliance is not damaged. Repair any damage.

Switch the appliance immediately off after finishing your work.

Never remove the collection bag when the machine is being operated. Always switch the machine off before attaching or removing the collection bag.

Do not store the appliance in enclosed places just after being switched off but let it cool down outdoors instead.

Never keep the unit with petrol in the tank inside a building where petrol vapours could get in contact with open fire or sparks.

When the appliance is not going to be used for a long time, store it with an empty tank.

Replace any defective muffler.

Do not change the controlled engine setting and do not rev the engine up.

Maintenance



Switch the engine off and remove the socket plug before any work on the engine. Wait until all rotating parts have stopped and the appliance has cooled down.

Keep the appliance, especially the tank and engine, clean at all times. Clean the ejection opening and cover at regular intervals.

Regularly remove any remainders of grass and weed to avoid an overheating of the shaft tube. Remainders of grass and weeds get caught under the protection cover avoiding a sufficient cooling of the shaft tube. Remove the remainders carefully with a screwdriver or a similar tool.

To reduce fire risks, periodically clean the cylinder flaps with compressed air and clear the silencer area to get rid of sawdust, branches, leaves or other debris.

To keep the danger of fire as low as possible the engine and exhaust pipe must be free from grass, leaves and excess grease.

Apply environment-friendly oil to all moving parts.

Check the collection bag at regular intervals for any wear and aging.

Repairs and works specified in these Instructions may only be performed by qualified authorised staff.

Use only original accessories and original spare parts. Components for which there are no instructions for exchanging should be replaced by the manufacturer only.

The use of non-original replacement parts is not permitted. We cannot guarantee correct functioning if non-original replacement parts are used.

Only a regularly maintained and treated appliance can serve as a satisfactory aid. Insufficient maintenance and care can lead to unforeseen accidents and injuries.

Guarantee

The guarantee solely covers inadequacies caused by material defect or manufacturing defect. Original payment voucher with the sales date needs to be submitted for any claim in the guarantee period.

The guarantee does not cover any unauthorised use such as appliance overloading, use of violence, damage as a result of any unauthorised interference or caused by foreign items. Failing to follow the operating and assembly instructions and common wear are also not included in the guarantee.

Serial No.:

Art. No.:

Year of production:

Service

Do you have any technical questions? Any claim? Do you need any spare parts or operating instructions? We will quickly help you and without needless bureaucracy at our web pages at www.guede.com in the Servicing part. Please help us be able to help you. In order to identify your device in case of claim we need the serial No., product No. and year of production. All this data can be found on the type label. To always have these data at hand, please enter them below.

Inspection and maintenance plan

 **Non-compliance with the maintenance plan may result in damage to the motor!**

Regular servicing period		Before any start-up	After 1 month	After 3 months	After 6 months	After 12 months	After 24 months
			5 Hours of operation	25 Hours of operation	50 Hours of operation	100 Hours of operation	250 Hours of operation
Engine oil (10W-40)	Inspection	✓					
	Change		✓		✓		
Air filter	Inspection	✓					
	Change				✓		
Spark plug	Inspection Clean					✓	
	Change						✓

Carry out the appropriate maintenance in the month specified or after being operated for the number of operating hours specified, depending on which occurs first.

Defects searching

Failures	Causes	Removal
The motor does not start	Start-Stop lever has not been pressed	Press the Start-Stop lever
	Primer pump not activated	Activate primer pump
	Lack of fuel	Add some fuel
	Bowden cables are too long	Adjust the Bowden cables using the coupling nut.
	Wrong fuel, storing without petrol tank being drained	Drain the fuel tank and carburettor. Add fresh petrol.
	Sooted spark plug (carbon residues on electrodes), electrodes distance too big	Clean the spark plug, check the plug thermal value, possibly change the plug, set the electrodes distance to 0.6-0.7 mm
	The spark plug is wet from petrol (oversaturated engine).	Dry the spark plug out and refit it.
Grass is not collected	Blocked channel	Clean the ejection channel
	Full collection bag	Empty the collection bag
	Too wet grass	Cut in dry weather

Технически данни

Бензинова косачка

Eco Wheeler EW 406-125

Арт. №	95555
Тип двигател	4-тактов двигател
Мощност на двигателя	2,1 kW (2,86 PS)
Работен обем	125 cm ³
Номинални обороти	3000 1/min
Ширина на косене	406 mm
Регулиране на височината на косене	25 45 65 mm
Капацитет на коша за трева	45 l
Гориво	Бензин
Система за стартиране	Ръчен стартер (с въже)
Моторно масло 0,45 l	10W40
Размер на колелата отзад	152 mm
Размер на колелата отпред	152 mm
Нетно/брутно тегло	17,5 / 22 kg

Данни за шума

Ниво на звуково налягане L_{pA} 1)	74,61 dB (A)
Измерено ниво на звукова мощност L_{WA} 2)	94,09 dB (A)
Гарантирано ниво на звукова мощност L_{WA} 3)	96 dB (A)

Измерено съгласно 1) EN ISO 5395-1:2013; 2) 3) 2000/14/EG;

1) Неопределеност $K = 3$ dB (A);

2) Неопределеност $K = 1,15$ dB (A), Носете антифони!

Данни за вибрациите

Общите стойности на вибрациите (триосна векторна сума) са определени съгласно EN ISO 5395-1:2013

Стойност на вибрационните емисии a_{hV}

макс. 4,0 m/s²

Неопределеност $K = 1,5$ m/s²

ПРЕДУПРЕЖДЕНИЕ: Нивото на вибрациите може да варира според начина на използване на електроинструмента и е възможно да надхвърли стойността, посочена в този информационен лист. Посоченото ниво на вибрации може да се използва за сравнение на различни инструменти.

Може да се използва за предварителна оценка на експозицията.

При оценка на нивото на излагане на вибрации трябва да се вземат предвид и периодите, когато уредът е изключен или работи, но реално не извършва работа. Това може значително да намали общото излагане за целия работен период.

Определете допълнителни мерки за безопасност за защита на оператора от въздействието на вибрациите, като например: поддържайте уреда и принадлежностите, дръжте ръцете топли, организирайте работните процеси.

Преди да използвате уреда, прочетете и разберете инструкциите за експлоатация. Запознайте се с органите за управление и с правилния начин на работа. Спазвайте всички мерки за безопасност, посочени в сервисното ръководство. Отнасяйте се отговорно към трети лица. Операторът носи отговорност за инциденти или рискове за трети лица. При съмнения относно свързването и работата, моля, обърнете се към нашия център за обслужване на клиенти

Определени условия за употреба

Косачката е предназначена за косене на тревни площи и затревени терени с максимален наклон до 20° в частни дворове и любителски градини.

Не използвайте този продукт по начин, различен от описания за нормална употреба. Неспазването на действащите общи разпоредби и указанията в това ръководство освобождава производителя от отговорност за щети.

Използвайте уреда само на открито; никога не го използвайте в затворени и слабо проветрени помещения.

Косачката не трябва да се използва за рязане на храсти, живи плетове и гъсталаци, за рязане и мулчиране на увивни растения, нито за косене на тревни площи по покриви или в балконски сандъчета. Също така не използвайте косачката като дробилка за мулчиране на дървесни изрезки и жив плет или за изравняване на неравности по терена.

Изисквания към обслужващия персонал

Обслужващият персонал трябва внимателно да прочете Инструкциите за експлоатация преди използване на уреда.

Този уред не е предназначен за използване от лица (включително деца) с ограничени физически, сетивни или умствени способности или с недостатъчен опит и/или знания, освен ако са под надзора на лице, отговорно за тяхната безопасност, или са получили от него указания за безопасна работа с уреда.

Квалификация: Освен подробните инструкции от специалист, не е необходима специална квалификация за работа с уреда.

Минимална възраст: С уреда могат да работят само лица над 16 години. Изключение се допуска за млади обучавани с цел придобиване на знания под надзора на инструктор в рамките на професионално обучение.

Местните разпоредби могат да определят минималната възраст на потребителя.

Обучение: За работа с уреда е необходимо съответно обучение от специалист или запознаване с Инструкциите за употреба. Не се изисква специално обучение.

Действия при авария

Риск от нараняване

Никога не поставяйте ръце или крака близо до въртящите се части. Винаги стойте на разстояние от отвора за изхвърляне.

Опасност от изгаряния!

При работа някои части на уреда се нагряват силно. Не докосвайте нагорещени елементи, напр. двигателя и шумозаглушителя.

Окажете първа помощ според вида на нараняването и възможно най-бързо потърсете квалифицирана медицинска помощ. Предпазете пострадалия от допълнителни увреждания и го успокойте. За случай на инцидент, съгласно DIN 13164, работното място трябва да разполага с аптечка. Задължително подменяйте незабавно всички използвани материали в аптечката. При търсене на помощ посочете следната информация

1. Място на инцидента
2. Вид на инцидента
3. Брой пострадали
4. Вид(ове) на нараняванията

Символи



Внимание!



За да намалите риска от нараняване, прочетете ръководството за употреба



Носете предпазни средства за слуха.
Носете защитни очила.



Носете защитни обувки, устойчиви на срязване, със защитна подметка и стоманено бомбе!



Бързо



Бавно



Изключете двигателя и извадете щепсела от контакта, преди да извършвате каквато и да е работа по двигателя.

Предупреждение за изхвърчащи предмети

1. Проверете нивото на маслото и долейте при необходимост.
2. Заредете с бензин.

	Натиснете праймера 3 пъти, ако двигателят е топъл. Натиснете праймера 6 пъти, ако двигателят е студен. Събиране
	Косене
	Внимание: горещи повърхности!
	Внимание: опасно напрежение!
	Внимание: остри ножове. Ножовете продължават да се въртят за кратко след изключване на уреда.
	Осигурете на околните безопасно разстояние от машината (мин. 5 м).
	Изключете двигателя преди всякаква работа по него.
	Пушенето и използването на открит огън са забранени.
	
	Дръжте машината далеч от деца.
	Уредът трябва да се съхранява на сухо място и да бъде защитен от замръзване.
	Гарантирано ниво на звукова мощност L _{WA}
	Пазете от влага по всяко време.
	Тази страна нагоре

Предупреждения за безопасност

Прочетете всички предупреждения за безопасност и всички инструкции. Неспазването на предупрежденията и инструкциите може да доведе до токов удар, пожар и/или сериозни наранявания. **Запазете всички предупреждения и инструкции за бъдещи справки.**

Дръжте децата и други лица, включително животни, на безопасно разстояние при работа с уреда. Минималното безопасно разстояние е 5 м.

Носете лични предпазни средства.

Носете подходящо защитно облекло, например здрави обувки с противоплъзгаща подметка, устойчиви дълги панталони, ръкавици, предпазни очила и защита за слуха!

При необходимост носете защитни ръкавици.

Използвайте уреда при дневна светлина или в добре осветена среда.

Преди употреба уредът трябва внимателно да се огледа. Работете само с уреди в изправно състояние. Ако забележите дефекти, които биха могли да представляват опасност за оператора, използвайте уреда едва след отстраняването им.

Огледайте внимателно терена, на който ще използвате уреда, и отстранете всички предмети, които могат да се закачат и да бъдат изхвърлени.

Бъдете нащрек, следете какво правите и работете с разум при работа с електроинструмент. Не използвайте електроинструмента, ако сте уморени или сте под въздействието на наркотици, алкохол или лекарства.

Никога не посягайте под корпуса, докато двигателят работи. Винаги стойте на разстояние от отвора за изхвърляне.

Избягвайте неволно стартиране на двигателя. Уверете се, че лостът за управление винаги е в положение „Start“, когато дърпате стартовото въже.

Горивото е силно запалимо.

Съхранявайте горивото само в подходящи съдове.

Зареждайте уреда само на открито и не в близост до открит пламък или запалени цигари.

Действия при авария

Внимавайте горивото да не прелее. Ако горивото прелее, двигателят не бива да се стартира. Почистете замърсяванията от уреда и не допускайте опити за запалване, докато изпаренията от горивото не се разсеят.

Преди първото пускане в експлоатация двигателят трябва да се напълни с моторно масло.

Проверявайте нивото на маслото всеки път преди пускане в експлоатация. При необходимост долейте моторно масло.

Опасност от отравяне!

Изгорелите газове, горивото и смазочните материали са токсични вещества. Вдишването на изгорели газове може да бъде фатално! Използвайте уреда само на открито; никога не го използвайте в затворени и слабо проветрени помещения.

Не използвайте уреда в затворени пространства, където могат да се натрупат опасни газове въглероден оксид.

Преди всяка употреба винаги правете визуална проверка за повреди по уреда, особено по режещите инструменти, елементите за закрепване или целия режещ възел.

Косачката не трябва да се използва без монтиран пълен кош за трева или без самозатварящото се, сваляемо предпазно устройство на отвора за изхвърляне.

Преди пускане в работа проверете дали всички винтове и щекерни съединения и предпазни устройства са здраво закрепени и добре затегнати, както и дали всички подвижни части се движат плавно.

Преди всяко стартиране проверявайте дали всички блокировки за пускане и бутоните работят правилно.

Строго е забранено предпазните устройства на уреда да се демонтират, променят или използват не по предназначение, както и да се монтират предпазни устройства от други производители.

Строго е забранено да се променят или манипулират каквито и да е запечатани устройства за регулиране на оборотите на двигателя.

Уредът не трябва да се използва, ако е повреден или ако предпазните устройства са дефектни. Подменете всички износени и повредени части.

Не стартирайте двигателя, преди краката ви да са на безопасно разстояние от режещите инструменти.

Не накланяйте уреда при стартиране.

Не стартирайте уреда, когато стоите пред отвора за изхвърляне.

Заставайте стабилно, особено по наклони. Не работете по прекалено стръмни склонове. Бъдете особено внимателни при смяна на посоката на движение по наклон.

Опасно е да косите по склонове, в канавки, по насипи или в близост до сметища и подобни места.

Не се протягвайте прекалено. Винаги стъпвайте стабилно и пазете равновесие. Внимавайте при движение назад – има риск да се спънете!

Осигурете достатъчно осветление или добри светлинни условия при работа с машината. Недостатъчната осветеност/лошите светлинни условия са сериозен риск за безопасността.

Не използвайте уреда при лошо време, особено ако има опасност от буря.

Когато е възможно, избягвайте работа с уреда върху мокра трева.

Вървете! Никога не тичайте!

Бъдете максимално внимателни при обръщане и когато придърпвате уреда към себе си.

Изключвайте косачката, когато я носите или наклоняте, както и когато се намирате извън тревната площ. Изчакайте всички въртящи се части да спрат напълно.

Ако попаднете на чужд предмет или уредът започне да вибрира, изключете уреда и извадете щепсела от контакта. Проверете дали уредът не е повреден. Отстранете всички повреди.

Изключете уреда незабавно след приключване на работата.

Никога не сваляйте торбата за събиране, докато машината работи. Винаги изключвайте машината, преди да поставите или свалите торбата за събиране.

Не прибирайте уреда в затворени помещения веднага след изключване — оставете го да изстине напълно.

Никога не съхранявайте уреда с бензин в резервоара в сграда, където бензиновите пари могат да влязат в контакт с открит пламък или искри.

Ако уредът няма да се използва дълго време, съхранявайте го с празен резервоар.

Сменете всеки повреден шумозаглушител.

Не променяйте регулировките на двигателя и не го форсирайте.

Поддръжка



Изключете двигателя и извадете щепсела и изчакайте да се машината да се охладите преди да започнете каквато и да е работа по двигателя.

Поддържайте уреда, особено резервоара и двигателя, винаги чисти. Почиствайте редовно отвора за изхвърляне и капака.

Редовно отстранявайте остатъци от трева и плевели, за да предотвратите прегряване на тръбата на вала. Остатъците от трева и плевели се задържат под предпазния капак и пречат на достатъчното охлаждане на тръбата на вала. Отстранявайте ги внимателно с отвертка или подобен инструмент.

За да намалите риска от пожар, периодично почиствайте ребрата на цилиндъра със сгъстен въздух и почиствайте зоната около заглушителя от стъргодини, клонки, листа и други отпадъци.

За да сведете до минимум опасността от пожар, двигателят и изпускателната тръба трябва да са без трева, листа и излишна грес.

Нанесете екологично масло върху всички движещи се части.

Проверявайте редовно торбата за събиране за износване и стареене.

Ремонтите и дейностите, посочени в тези инструкции, могат да се извършват само от квалифициран, оторизиран персонал.

Използвайте само оригинални принадлежности и оригинални резервни части. Компоненти, за които няма указания за подмяна, трябва да се заменят единствено от производителя.

Използването на неоригинални резервни части не е разрешено. Не можем да гарантираме правилна работа при използване на неоригинални резервни части.

Само уред, който се поддържа и обслужва редовно, може да бъде надежден помощник. Недостатъчната поддръжка и грижа могат да доведат до непредвидени злополуки и наранявания.

Гаранция

Гаранцията покрива единствено несъответствия, причинени от дефект в материала или производствен дефект. За предявяване на рекламация в гаранционния срок е необходимо да представите оригиналния платежен документ с дата на покупка.

Гаранцията не покрива неразрешена употреба, като претоварване на уреда, грубо/насилствено използване, повреди вследствие на нерегламентирана намеса или причинени от чужди предмети. Неспазването на инструкциите за експлоатация и монтаж, както и нормалното износване, също не се включват в гаранцията.

Сериен №:

Арт. №:

Година на производство:

Сервиз

Имате технически въпроси? Искате да подадете рекламация? Нуждаете се от резервни части или инструкции за работа? Ще ви помогнем бързо и без излишна бюрокрация на нашия сайт www.guede.com в раздел „Сервиз“. Помогнете ни, за да ви помогнем: за идентифициране на устройството при рекламация са необходими сериен №, продуктово № и година на производство. Тези данни се намират на табелката с данни. За да са ви винаги поддръжка, въведете ги по-долу.

План за проверка и поддръжка

 **Неспазването на плана за поддръжка може да доведе до повреда на двигателя!**

Редовен сервизен интервал		Преди всяко пускане	След 1 месец	След 3 месеца	След 6 месеца	След 12 месеца	След 24 месеца
			5 работни часа	25 работни часа	50 работни часа	100 работни часа	250 работни часа
Моторно масло (10W-40)	Проверка	✓					
	Смяна		✓		✓		
Въздушен филтър	Проверка	✓					
	Смяна				✓		
Запалителна свещ	Проверка					✓	
	Почистване						
	Смяна						✓

Извършвайте съответната поддръжка през посочения месец или след посочения брой работни часове – според това кое настъпи първо.

Търсене на неизправности

Повреди	Причини	Отстраняване
Двигателят не стартира	Лостът Start-Stop не е натиснат	Натиснете лоста Start-Stop
	Помпичката за подкачване не е задействана	Задействайте помпичката за подкачване
	Недостатъчно гориво	Долейте гориво
	Жилата на Боудън са твърде дълги	Регулирайте жилата на Боудън с помощта на съединителната гайка.
	Неподходящо гориво, съхранение без източване на резервоара	Източете резервоара и карбуратора. Налейте прясно гориво.
	Омаслена/нагорясала свещ (въглеродни отлагания по електродите), твърде голямо междинно разстояние между електродите	Почистете свещта, проверете топлинното ѝ число, при нужда я сменете и настройте разстоянието между електродите на 0,6–0,7 mm
	Свещта е мокра от бензин (двигателят е препълнен).	Подсушете свещта и я монтирайте обратно.
Тревата не се събира	Запушен канал Торбата за събиране е пълна Тревата е твърде мокра	Почистете канала за изхвърляне Изпразнете торбата за събиране Косете при сухо време